

SUBCOURSE
OD1646

EDITION
8

BANDSAW OPERATIONS

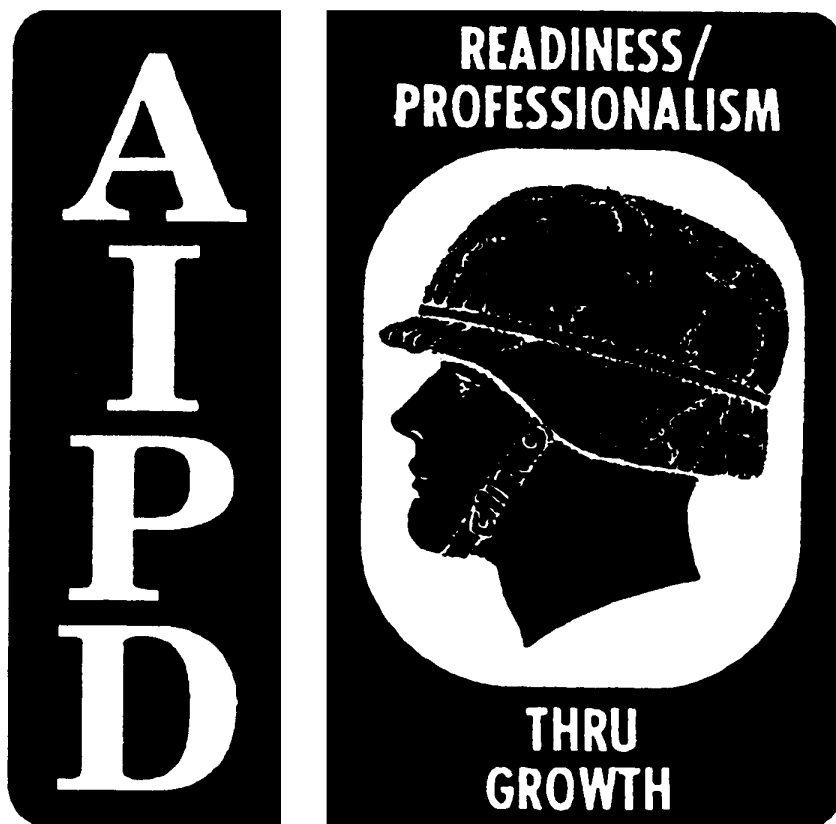

THE ARMY INSTITUTE FOR PROFESSIONAL DEVELOPMENT
ARMY CORRESPONDENCE COURSE PROGRAM

US ARMY REPAIR SHOP TECHNICIAN WARRANT
OFFICER ADVANCED CORRESPONDENCE COURSE

MOS/SKILL LEVEL: 441A

BANDSAW OPERATIONS

SUBCOURSE NO. OD1646

US Army Correspondence
Course Program

7 Credit Hours

GENERAL

The purpose of this subcourse is to introduce the use of the bandsaw machine and to describe the methods used in maintaining and troubleshooting this machine for possible problems or malfunctions.

The scope of this subcourse covers a description of types of bandsaw machines used in the U.S. Army. The general methods for using these machines are also discussed. Included in the subcourse are instructions for maintaining and troubleshooting the bandsaw.

Seven credit hours are awarded for successful completion of this subcourse. It consists of two lessons divided into tasks as follows:

Lesson 1: USES OF THE BANDSAW

TASK 1: Describe the use of the bandsaw machine.

Lesson 2: BANDSAW MAINTENANCE AND TROUBLESHOOTING

TASK 1: Describe the methods used to repair and adjust the bandsaw.

TASK 2: Describe the procedures for troubleshooting the bandsaw.

BANDSAW OPERATIONS - OD1646

TABLE OF CONTENTS

Section	Page
TITLE	i
TABLE OF CONTENTS	ii
Lesson 1: USES OF THE BANDSAW	1
Task 1: Describe the use of the bandsaw machine	1
Practical Exercise 1	50
Answers to Practical Exercise 1	52
Lesson 2: BANDSAW MAINTENANCE AND TROUBLESHOOTING	53
Task 1: Describe the methods used to repair and adjust the bandsaw	53
Task 2: Describe the procedures for troubleshooting the bandsaw	65
Practical Exercise 2	85
Answers to Practical Exercise 2	87
REFERENCES	89

BANDSAW OPERATIONS - OD1646 - LESSON 1/TASK 1

LESSON 1

USES OF THE BANDSAW

TASK 1. Describe the use of the bandsaw machine.

CONDITIONS

Within a self-study environment and given the subcourse text, without assistance.

STANDARDS

Within three hours

REFERENCES

No supplementary references are needed for this task.

1. Introduction

A sawing machine is a machine tool designed to cut off bar stock, tubing, pipe, or any metal stock within its capacity, or to cut sheet stock to desired contours. The sawing machine functions by bringing a saw blade containing cutting teeth in contact with the workpiece to be cut, and drawing the cutting teeth through the workpiece. The sawing machine is much faster and easier than hand sawing, and is used principally to produce an accurate square or mitered cut on rectangular or cylindrical material.

One of the two common types of sawing machines used for metal cutting in the machine shop is the bandsaw machine. The bandsaw machine cuts by drawing a continuous metal band, called a bandsaw blade, across the workpiece. The bandsaw blade is supported and driven by a drive wheel and an idler wheel.

This subcourse describes bandsaw operations and maintenance. This lesson introduces three common models of bandsaw machines and describes their use. In lesson two, the methods for maintaining,

BANDSAW OPERATIONS - OD1646 - LESSON 1/TASK 1

repairing, and troubleshooting these three bandsaw machines will be discussed.

2. Types of Metal Cutting Bandsaws

Metal cutting bandsaw machines fall into two basic categories: horizontal machines and vertical machines. Vertical bandsaw machines are more commonly used. On vertical machines, the blade's cutting position is vertical and cuts into the side of the stock. The blade rotates on a fixed track between the idler wheel mounted above the worktable and the drive wheel mounted beneath the worktable. The stock is moved against the blade to make the cut. On the horizontal bandsaw machine, the cutting position of the bandsaw blade is horizontal and cuts downward into the stock. The drive and idler wheels are positioned lengthwise on the sawing machine frame, which pivots from a corner of the sawing machine bed. With the horizontal machine, the stock is fixed rigidly in a vise to the bed of the machine, and the blade is fed downward into the workpiece. The horizontal bandsaw machine is used primarily for cutting stock to length, either at right angles or to any desired miter angle. The vertical machine is more versatile and can be used for contour cutting, filing, and polishing, as well as for simple stock cutting.

a. *Vertical Bandsaw.* The vertical metal cutting bandsaw machine, being the more common of the two types of bandsaw machines, is usually identified as a "bandsaw machine" without using the word "vertical." A typical bandsaw machine (figure 1 on the following page) is driven by an electric motor through a belt transmission which permits adjustment of the blade speed through a range of speeds. The table may be tilted front-to-back or sideways to make mitered cuts. The metal cutting bandsaw machine does not require preformed bandsaw blades. An electric butt welder and grinding wheel are fastened to the sawing machine. The welder is used to weld a length of blade into a continuous band, and the grinding wheel is used to remove beads caused by the welding. Since the machine can weld its own blades, internal cutting is possible. When making internal cuts, the blade is inserted through a hole cut in the workpiece and is then welded into a band and mounted to the machine. After cutting the internal shape in the piece, the band is cut so that it can be removed.

An attachment for the metal cutting bandsaw twists the blade 30° or 90° so that stock which normally could not be cut because of insufficient clearance of the sawing machine column can be successfully cut. Other attachments permit the use of band files and polishing bands in place of the bandsaw blade. Adjustable guides for holding and feeding workpieces are also provided. The machine has a power feed mechanism operated by counterweights. Forced air for chip removal is supplied by an air pump in the base of the machine.

FIGURE 1. THE VERTICAL BANDSAW MACHINE.

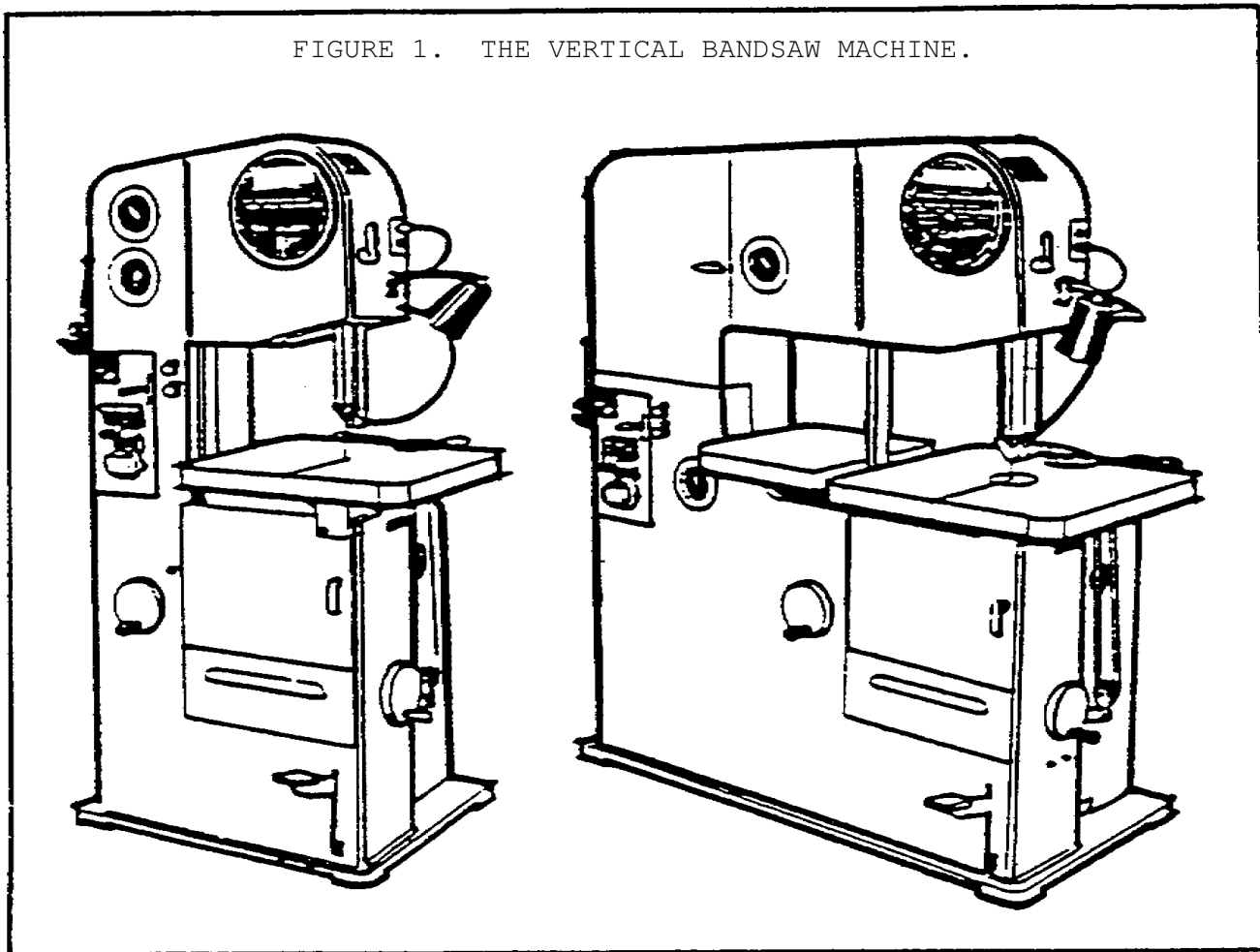

b. *Horizontal Bandsaw.* The typical metal cutting horizontal bandsaw machine (figure 2 on the following page) is a floor-mounted machine used for simple cutting of solid steel, tubing, and odd shaped material. The material to be cut is mounted in a vise attached to the bed of the machine. An electric motor drives the bandsaw blade through a belt and pulley arrangement from which three speeds may be obtained. The sawing machine frame, upon

BANDSAW OPERATIONS - OD1646 - LESSON 1/TASK 1

which the drive wheel, idler wheel, bandsaw blade, and motor are mounted, pivots from one corner of the sawing machine bed. The frame is counterbalanced by a tension spring between the frame and the bed. Feed is controlled by positioning a sliding weight along a bar fixed to the top side of the sawing machine frame. A dashpot is positioned between the frame and bed to stabilize the feed movement and prevent any quick movement of the frame that could cause damage to the bandsaw blade. The vise used to hold the material being cut is a quick-positioning type and can be adjusted easily to any angle. An adjustable workpiece stop is provided for rapid positioning of production work pieces.

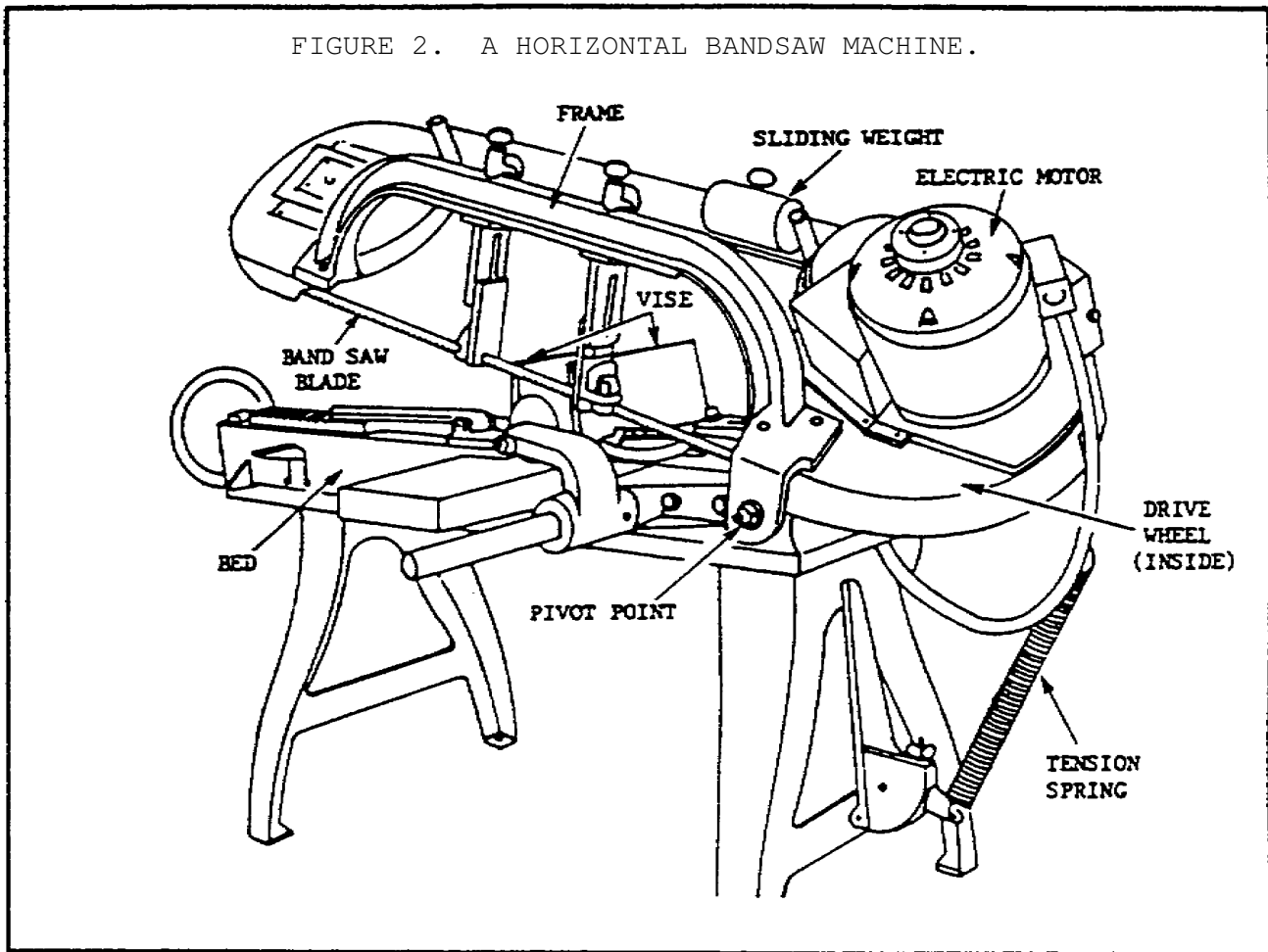

3. Models of Vertical Bandsaw Machines

Since the vertical bandsaw machine is more common than the horizontal type, three models of vertical bandsaw machines will be considered in this subcourse.

BANDSAW OPERATIONS - OD1646 - LESSON 1/TASK 1

a. *Model 1612-0.* Model 1612-0 is a floor mounting, metal cutting, vertical bandsaw machine (figure 3). It has a 16 inch throat depth, and can accommodate a saw blade or a file band. The heavy, ribbed, cast iron table is 24 x 24 inches; it can be adjusted for a tilt of 10° to the left or 45° to the right. Precision insert guides are furnished with the machine to cover all sizes of saw band from 1/16 to 3/4 inch. The drive motor is a 208 volt, 60 cycle, 3 phase electric motor. Power is transmitted from the drive motor to a variable speed pulley, and then to the two-speed transmission which in turn drives the lower

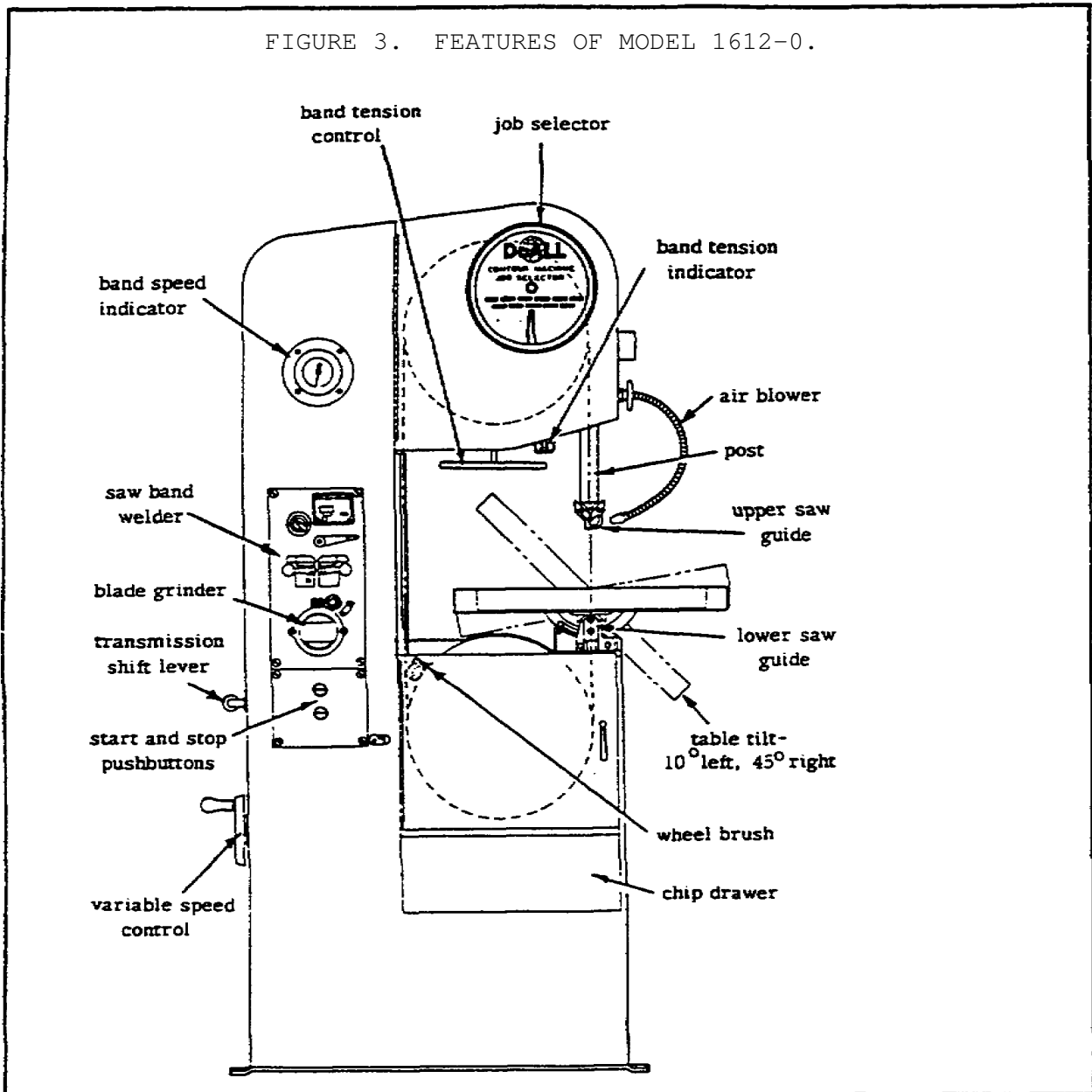

BANDSAW OPERATIONS - OD1646 - LESSON 1/TASK 1

saw band wheel. A saw blade welder with grinder is mounted in the machine column.

b. *Model 2612-1M.* The model 2612-1M is a floor mounting, metal cutting, vertical bandsaw machine. It has a 24 inch throat depth and can accommodate a 1 inch maximum bandsaw blade and a 1/2 inch maximum band file. The worktable (figure 4 on the following page) measures 26 x 26 inches; it can be manually titled up to 45° to the right and up to 5° to the left. Power is fed from the 220 volt, 60 cycle motor through a variable speed pulley to the three-speed transmission (figure 5 on page 8). The model 2612-1M bandsaw machine has an integral butt welder and grinder.

c. *Model 2614-1.* Model 2614-1 is a floor mounted, metal cutting, vertical bandsaw machine (figure 6 on page 9). It has a 26 inch throat depth. The heavy duty 30 x 30 inch table has a removable center disk. The table can be tilted manually to a maximum of 5° to the left and 45° to the right. The five horsepower motor drives a variable speed pulley which, in turn, drives the three-speed transmission. The bandsaw machine is equipped with a butt welder and grinder.

NOTE

In the remainder of this subcourse, the term "bandsaw machine" refers only to the vertical metal cutting bandsaw machine. Operations for the horizontal metal cutting bandsaw machine will not be discussed.

4. Uses of Bandsaw Machines

The bandsaw machine is used for external and internal sawing. With the use of attachments, the bandsaw machine can also serve a variety of other functions. Band files and polishing bands can be used in place of the bandsaw blade for filing and polishing operations. A disk cutting attachment permits the cutting of true circles. An angular blade guide attachment is furnished with most bandsaw machines. This attachment twists the bandsaw blade so that large or long workpieces that would not normally clear the bandsaw machine column can be cut. A miter guide attachment can be used to guide the workpiece at any convenient angle.

FIGURE 4. MODEL 2612-1M FEATURES - FRONT VIEW.

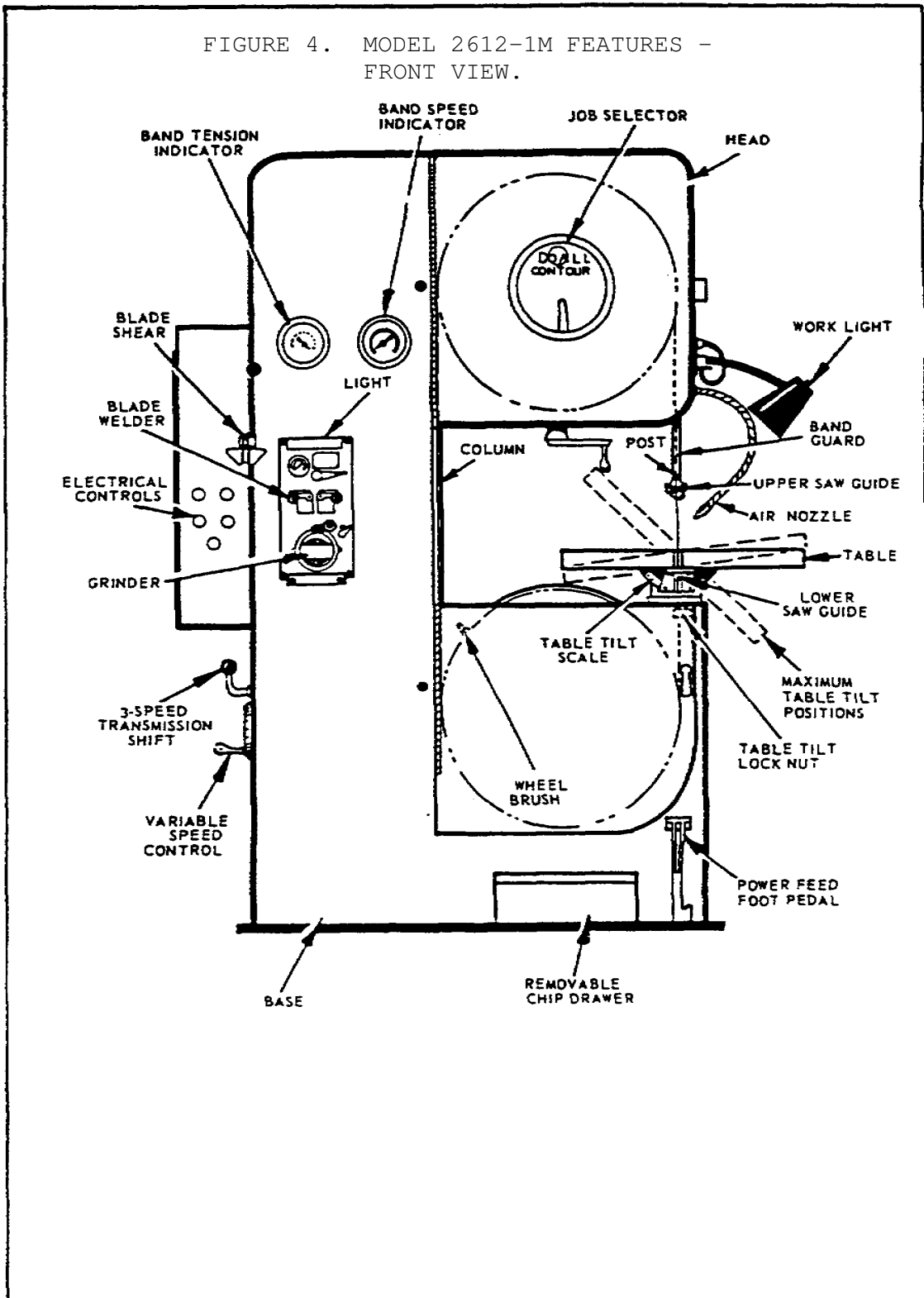
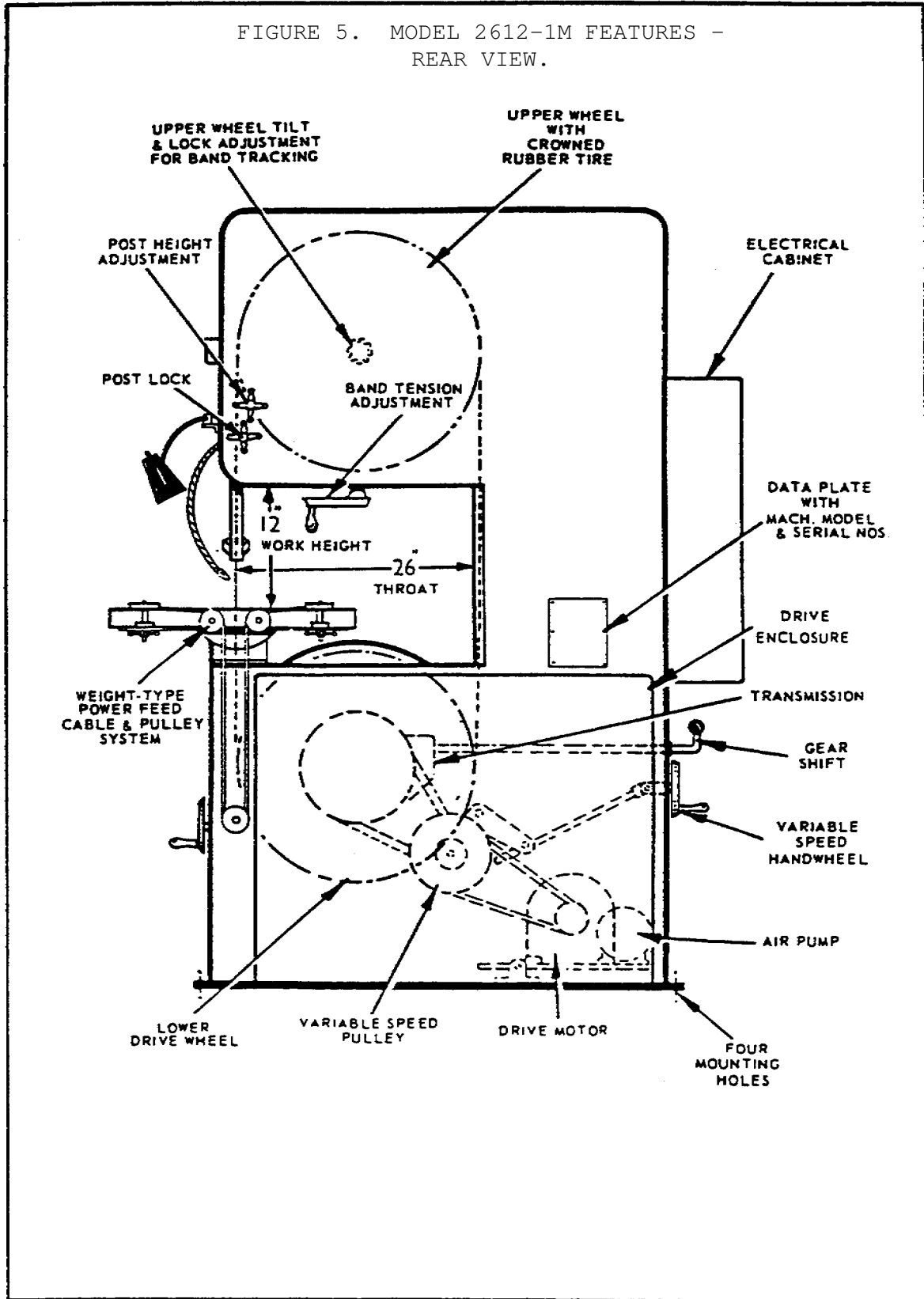
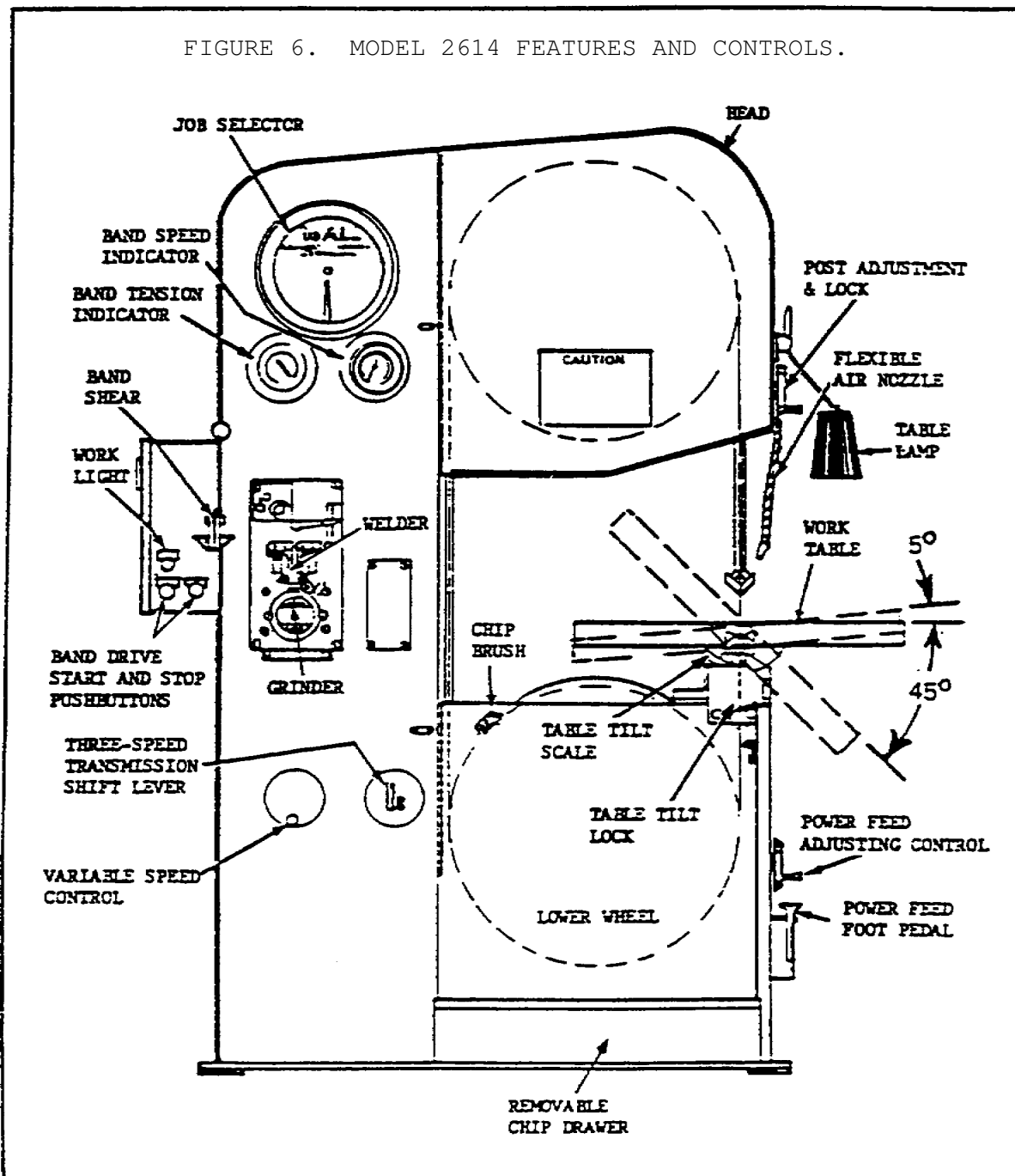

FIGURE 5. MODEL 2612-1M FEATURES - REAR VIEW.





a. *General Bandsawing Operations.* The bandsaw machine can be used for making external straight-line, curved, or contoured cuts. When power sawing with the bandsaw machine, proper blade and guide selection are important.

(1) *Blade Selection.* Bandsaw blades are manufactured in two forms. They are supplied in

BANDSAW OPERATIONS - OD1646 - LESSON 1/TASK 1

rolls of 50 to 500 feet for use on machines that have butt welders for forming their own blade bands. Bandsaw blades are also supplied in continuous welded bands in standard sizes for machines having no provisions for welding blade bands. All three models discussed in this subcourse have provisions for welding blade bands.

(a) *Characteristics of Blades.* Bandsaw blades are made from special alloy steel. The blades are made flexible by annealing the body of the blade and hardening only the teeth. Metal cutting bandsaw blades have their teeth set to produce a kerf, or cut, slightly wider than the thickness of the blade to prevent the blade from being pinched by the stock. The setting of the teeth for most bandsaw blades is called the raker setting. Raker tooth blades have one tooth bent to the right, the next tooth bent to the left, and the third tooth set straight (figure 7). The pitch of bandsaw blade teeth is the number of teeth per linear inch of the blade (figure 8 on the following page). For example, if a blade has 14 teeth per inch (tpi), it has a pitch of 14, or it may be referred to as a 14-pitch blade. Metal cutting bandsaw blades range from 6 to 32 teeth per inch. The finer tooth blades are used for sawing thin stock; the coarse tooth blades are used for sawing large stock and soft metal.

FIGURE 7. RAKER TOOTH SETTING.

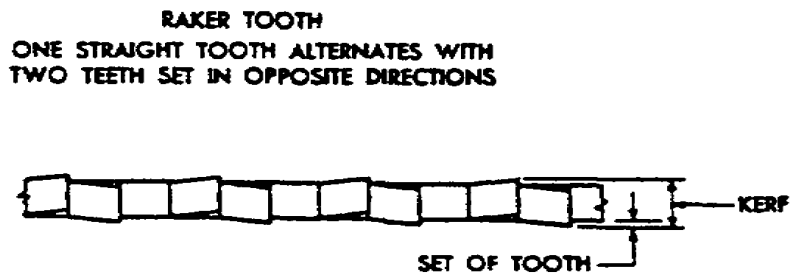

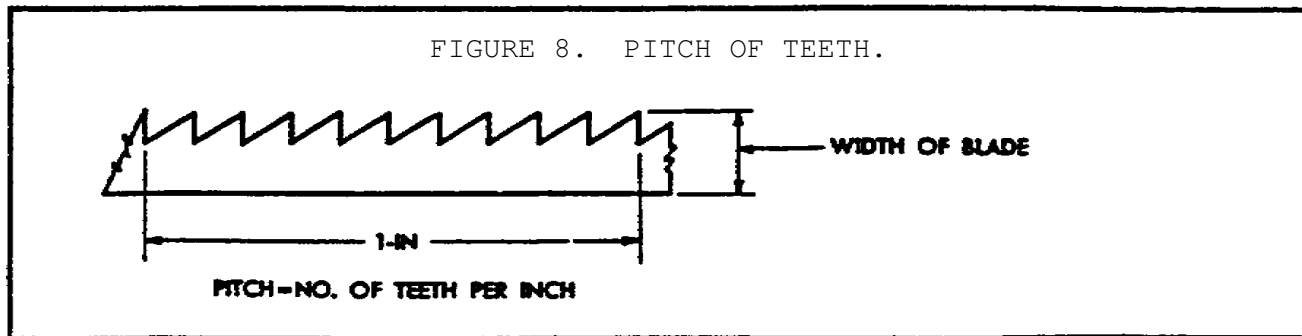

(b) *Selecting the Proper Blade.* Bandsaw blades are selected according to the type of material to be cut, the thickness of the material to be cut, and the sawing operation to be performed.

1 *Blade Pitch.* Soft or gummy materials and thick stock require coarse tooth blades to provide adequate chip clearance. Hard materials generally require finer tooth blades. Fine tooth blades are also necessary if a good finish is desired. Since two or three teeth of the bandsaw blade must be in contact with the workpiece at all times to prevent chatter and shearing of teeth, fine tooth blades are used to cut sheet metal and tubing. If sheet metal is too thin to meet this requirement with the finest tooth blade available, the metal should first be mounted on plywood, fiber, or thicker metal to stiffen it. Table 1, on the following page, may be used as a guide in selecting the proper pitch bandsaw blade for different metals and metal thicknesses. If the stock is exceptionally large, coarser tooth blades than those recommended for solid stock may be used. Remember, two or more teeth must contact the workpiece at all times to prevent shearing of the blade teeth. If the recommended pitch for solid stock fails to meet this requirement, a blade with finer pitch must be selected.

2 *Blade Width.* When straight sawing, the widest blade available of the proper pitch should be used. Thinner blades are required for contour sawing to prevent the body of the blade from rubbing the sides of the cut when cutting sharp curves. When curves or radii are to be cut on the bandsaw machine, the widest blade adaptable to the sharpest radius to be cut should be used. Narrow blades are more easily broken than wide blades and should be used only where necessary.

BANDSAW OPERATIONS - OD1646 - LESSON 1/TASK 1

TABLE 1. SELECTION OF BLADE PITCH.

MATERIAL	BANDSAW BLADE PITCH
Sheet metal, under 1/8 inch thick.....	24-32
Sheet metal, over 1/8 inch thick.....	18
Solid Stock:	
Aluminum.....	6-10
Brass.....	10-12
Bronze.....	12-14
Cast Iron.....	10-12
Copper.....	10-12
Steel, alloy.....	12-14
Steel, high-speed.....	12-14
Steel, machine.....	10-14
Steel, stainless.....	12-14
Steel, tool.....	12-14
Tubing, under 1/8 inch wall thickness.....	24-32
Tubing, over 1/8 inch wall thickness.....	18

Table 2 lists the blade sizes which can be used for cutting different size radii. If the proper size blade for the radius to be cut is not available, the next size narrower should be used.

TABLE 2. BANDSAWING RADIUS GUIDE.

RADIUS TO BE CUT (IN INCHES)	WIDTH OF BANDSAW BLADE TO USE (IN INCHES)
2 1/2 and larger.....	1/2
1 7/16 to 2 7/16.....	3/8
1 to 1 3/8.....	5/16
5/8 to 15/16.....	1/4
5/16 to 9/16.....	3/16
1/8 to 1/4.....	1/8

BANDSAW OPERATIONS - OD1646 - LESSON 1/TASK 1

(c) *Blade Wear.* Bandsaw blades become dull from prolonged use, but some conditions promote greater than normal wear on the blades. Blades dull quickly if used at too high a speed for the material being cut. Also, if the material to be cut is too hard for the pitch of the blade, abnormal wear will result. This can be caused by hard spots in cast iron or welded metal, and usually can be anticipated so that the operator can reduce the feed. Rubber and some fibers or plastics contain abrasive material that will dull saw blades regardless of the sawing speed and feed. Premature blade dulling often occurs from using too fine a pitch blade and from feeding too quickly.

(d) *Symptoms of Worn Blades.* Several symptoms appear when a bandsaw blade is dull. If the bandsaw blade cuts slowly or not at all when the workpiece is fed by hand, the blade is probably dull. Blade teeth which are bright on the cutting edge also indicate a dull blade. Another sign of a dull blade is when it becomes difficult to follow a line or when the blade forces to one side or the other. A dull blade is also indicated when the chips from cutting metals are granular (except for cast iron which produces granular chips with both sharp and dull blades). With the machine stopped, or with the bandsaw blade removed from the machine, run a finger slowly over the teeth in the cutting direction. If sharp edges cannot be felt, the blade is dull and should be replaced.

(2) *Guide Selection.* Standard saw guides are furnished with the bandsaw machines and are designed to guide the saw blade to a constant location. The standard guides are installed directly on the post and keeper block. Adjustable saw guide inserts allow the guides to be adjusted to the size of the saw blade to be used. Two special attachments, the angular blade guide and the miter guide, provide added capabilities to the bandsaw machine.

(a) *Adjusting Saw Guide Inserts.* Saw guide inserts are provided so that the guides can be adjusted for the size of saw blade to be used. The set of inserts marked for the width of saw band being used should be selected. The right hand insert (figure 9 on the following page) is placed in the milled slot of the guide, and its adjusting screw is tightened lightly so that the insert is able to slide in the slot but will still hold its

BANDSAW OPERATIONS - OD1646 - LESSON 1/TASK 1

position when it is released. Using the proper insert gage to match the saw band being used, place the gage in the opposite slot and adjust the insert so that it meets the two gaging edges. Then tighten the insert securely in place. Place the left hand insert in the slot and tighten the screw lightly. Then place the gage edgewise between the two inserts. Bring the left hand insert down so that it rests against the gage. When the gage is removed, the gap left will be the proper thickness for the saw band.

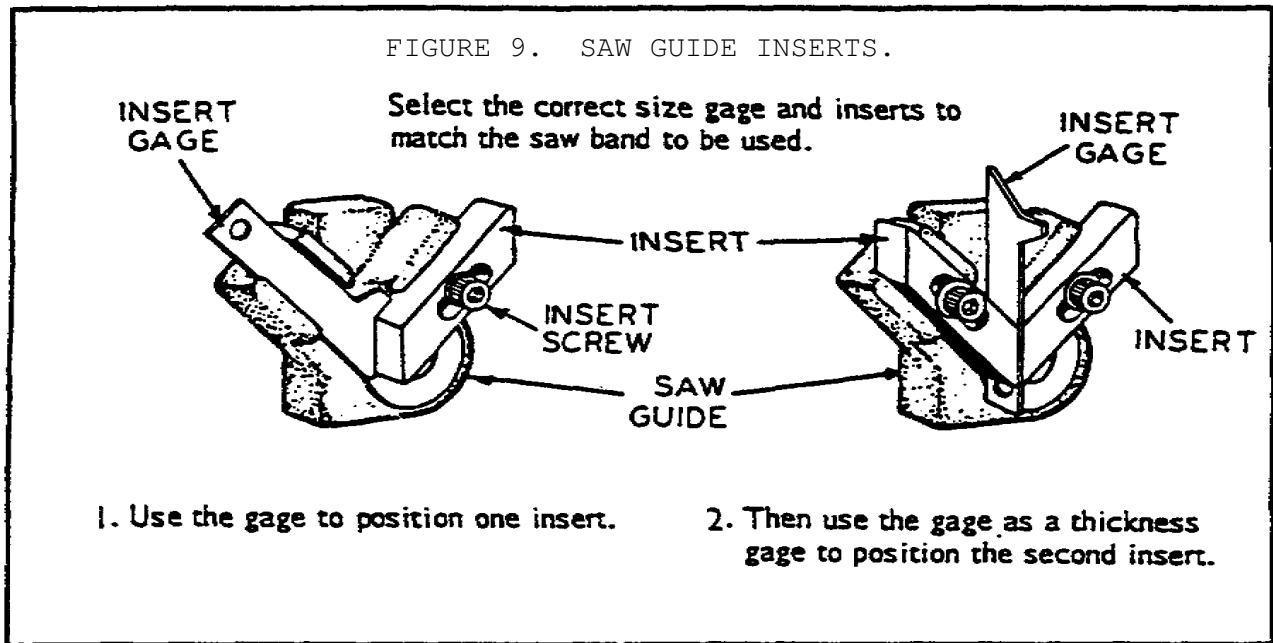

(b) *Angular Blade Guide.* The angular blade guide attachment is furnished with most metal cutting bandsaw machines. This attachment twists the bandsaw blade so that large or long workpieces that would not normally clear the bandsaw machine column can be cut. The blade is twisted 30° on some machines and 30° to 90° on others. The angular blade guide attachment consists of an upper bandsaw blade guide that attaches to the sawing machine post and a lower bandsaw blade guide that attaches to the frame beneath the table. Figure 10 on the following page shows 90° saw guide brackets (with guides and inserts installed on the bracket) as installed on the model 2612-1M bandsaw machine.

FIGURE 10. ANGULAR BLADE GUIDE ATTACHMENT.

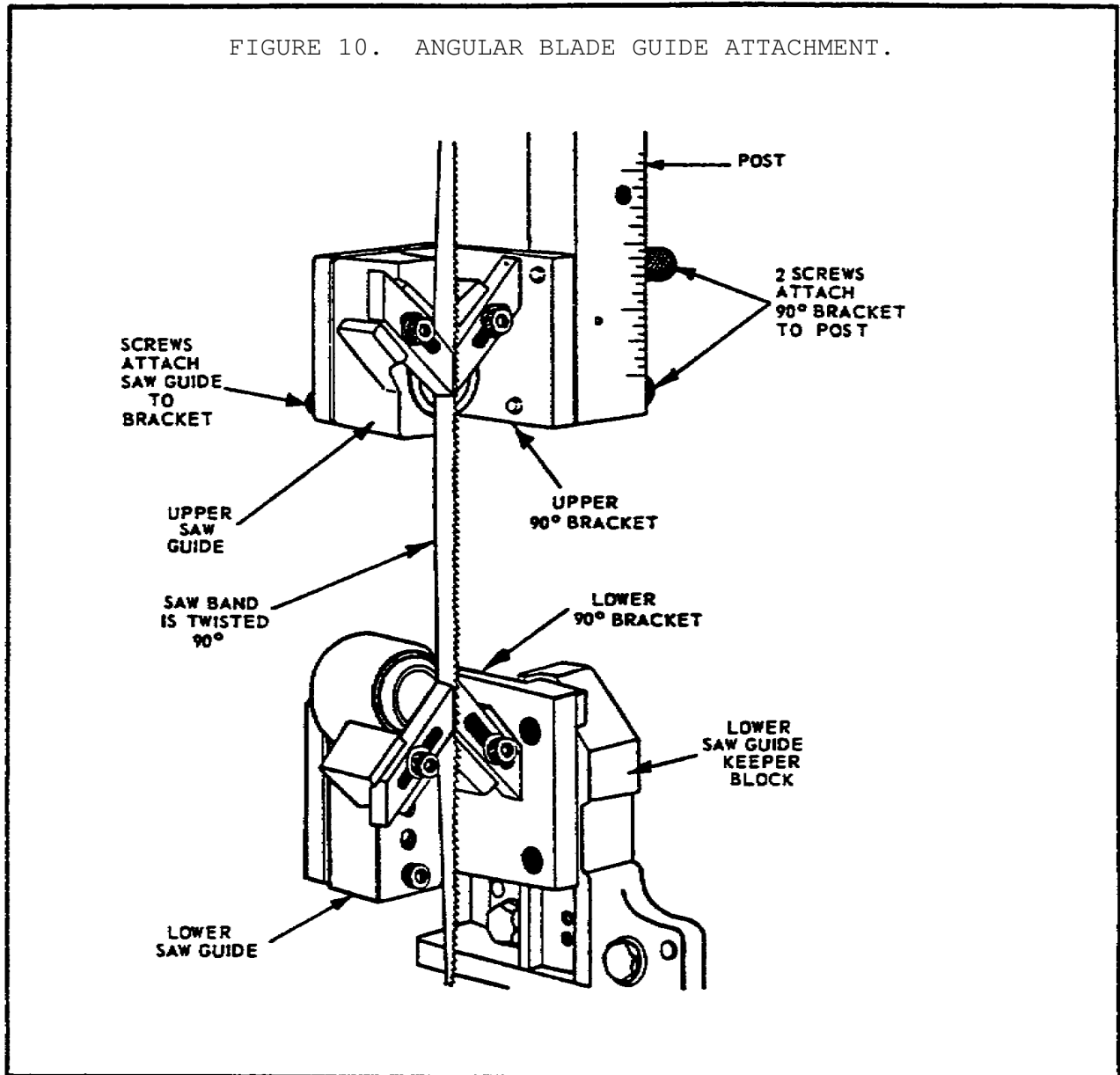

(c) *Miter Guide*. The miter guide attachment is a device used to support and guide workpieces to the bandsaw blade so that the workpiece may be cut at a specific angle. The attachment can be swiveled and locked to guide the workpiece at any convenient angle. On the three bandsaw machine models discussed in this subcourse, the mitering attachment is side mounting. When not in use, the attachment is swung up to the right and around on the slide rod so that it hangs below the table. Figure 11 on the following page shows a typical side mounting mitering attachment.

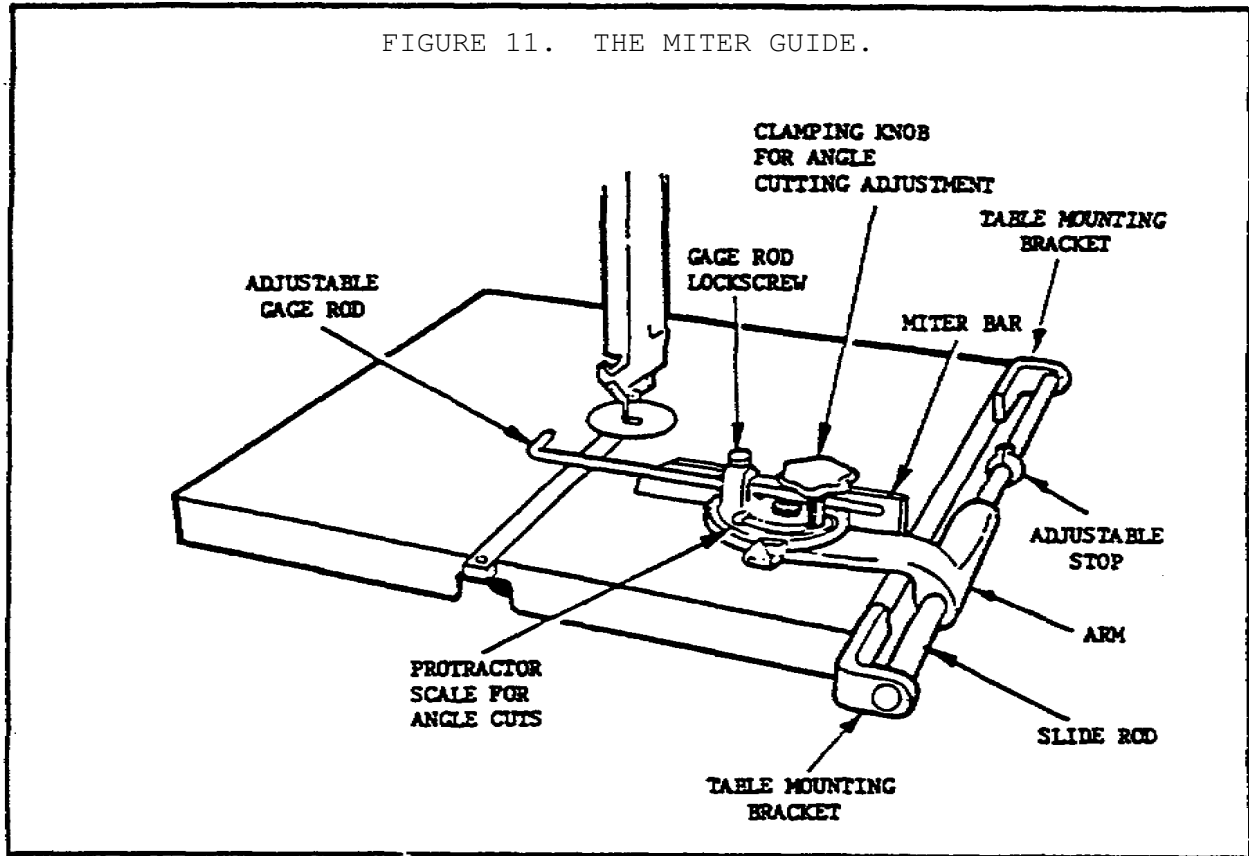

(d) *Rip Fence*. The rip fence accessory helps in making even, straight cuts. A typical rip fence is shown in figure 12 on the following page. In making a long cut with a rip fence as a guide, check to be sure that the saw band used is not worn on one side. This will cause the work to wander relative to the rip fence guide.

(e) *Disk Cutting Attachment*. The disk cutting attachment (figure 13 on page 18) permits cutting true circles, either internally or externally, or any diameter from 2 1/2 to 30 inches. This attachment is bolted to the post with capscrews and washers.

(f) *Screw Feed Attachment*. The screw feed device (figure 14 on page 18) is a machine tool attachment on some makes of bandsaw machines, and is a component part of other bandsaw machines. The screw feed accessory is used for precision contour sawing of heavy work. It is a hand-operated method of feeding the workpiece into the bandsaw blade or band file. The device is used with a work holding jaw to feed the workpiece into the blade at angles other than 90° to the blade.

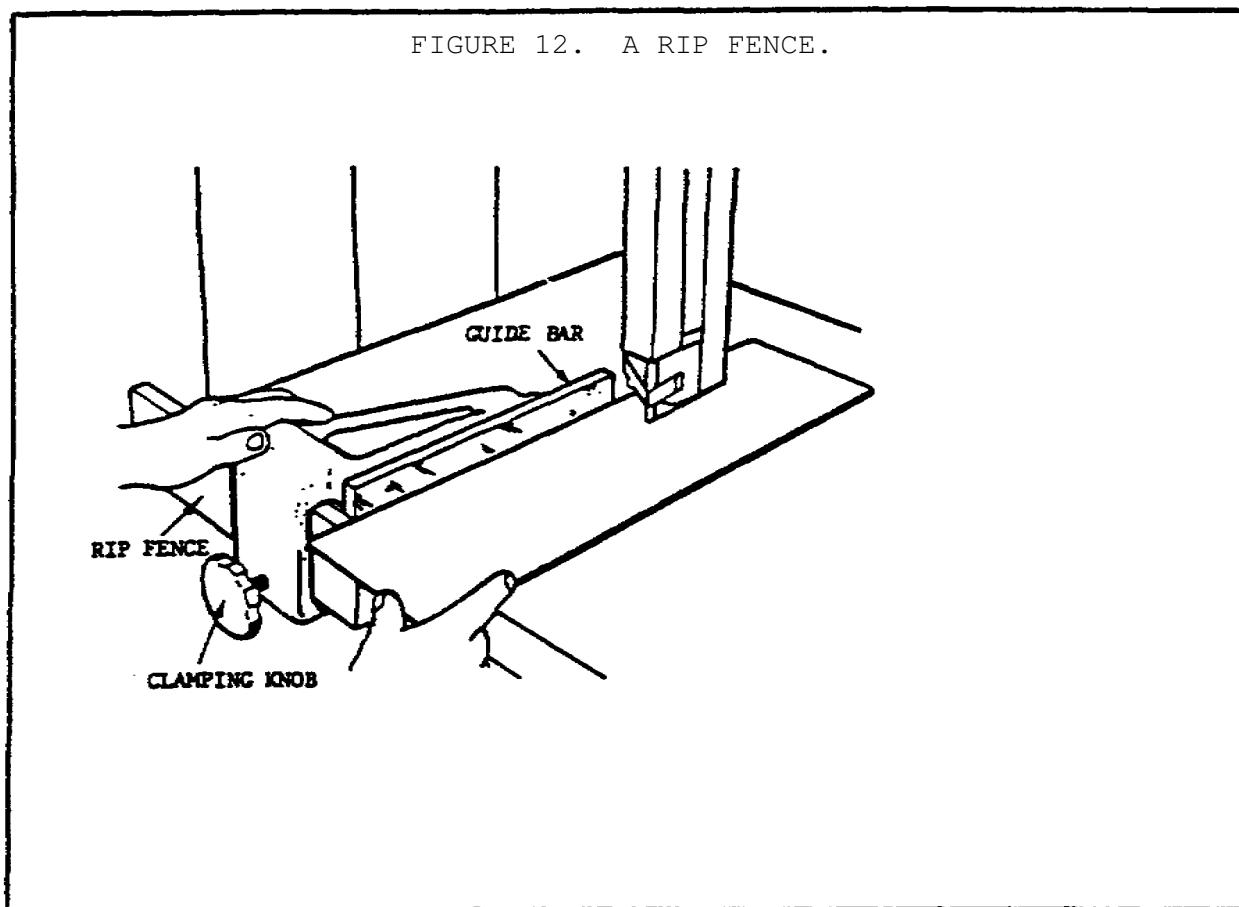

(3) *Band Tensioning.* It is essential that the saw band be correctly tensioned in order to obtain a maximum accuracy and cutting rate. Band tension is applied by turning the removable handcrank (tension handle) located below the saw head.

The band should be tightened to the proper tension indicated on the band tension scale mounted on the machine. The figures on this scale are recommended tensions and are based on the most common gages and pitches used. When using bands with coarser pitch or lighter gage, the tension should be reduced. The tension should be increased when using heavier bands. A new band may stretch slightly as it is being used. It is important to check the tension of the band so that it does not become too slack. Table 3 on page 19 gives the recommended tensions for all sizes of band tools.

(4) *Tracking the Band.* The upper wheel must be adjusted so that the band tracks correctly on both wheels. To accomplish this, the upper wheel can be tilted on its axis. Assuming that the saw band has

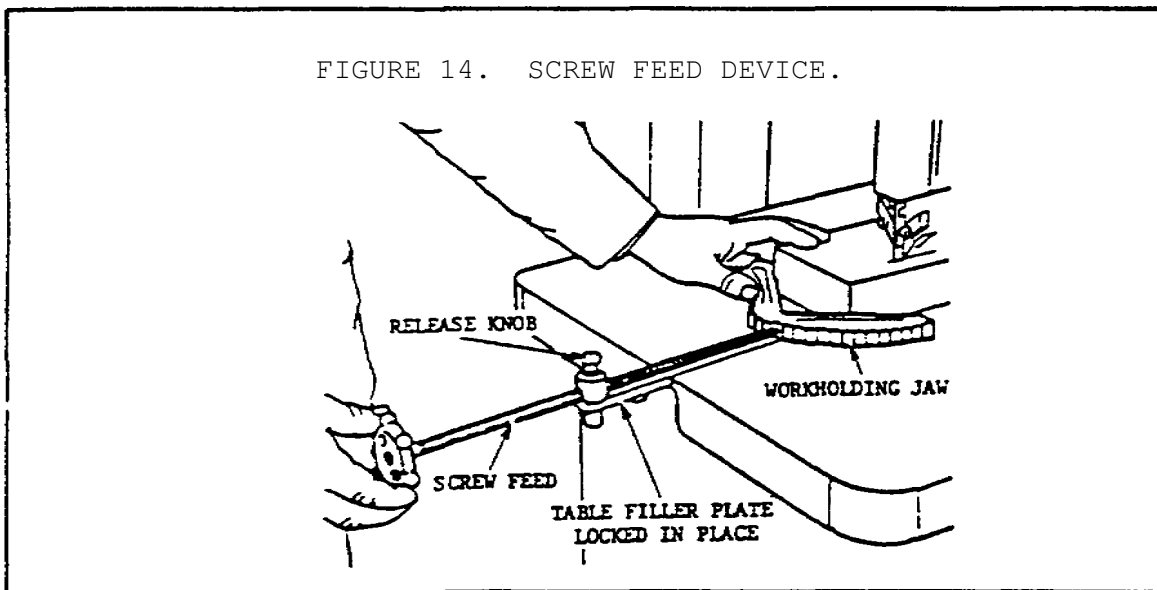
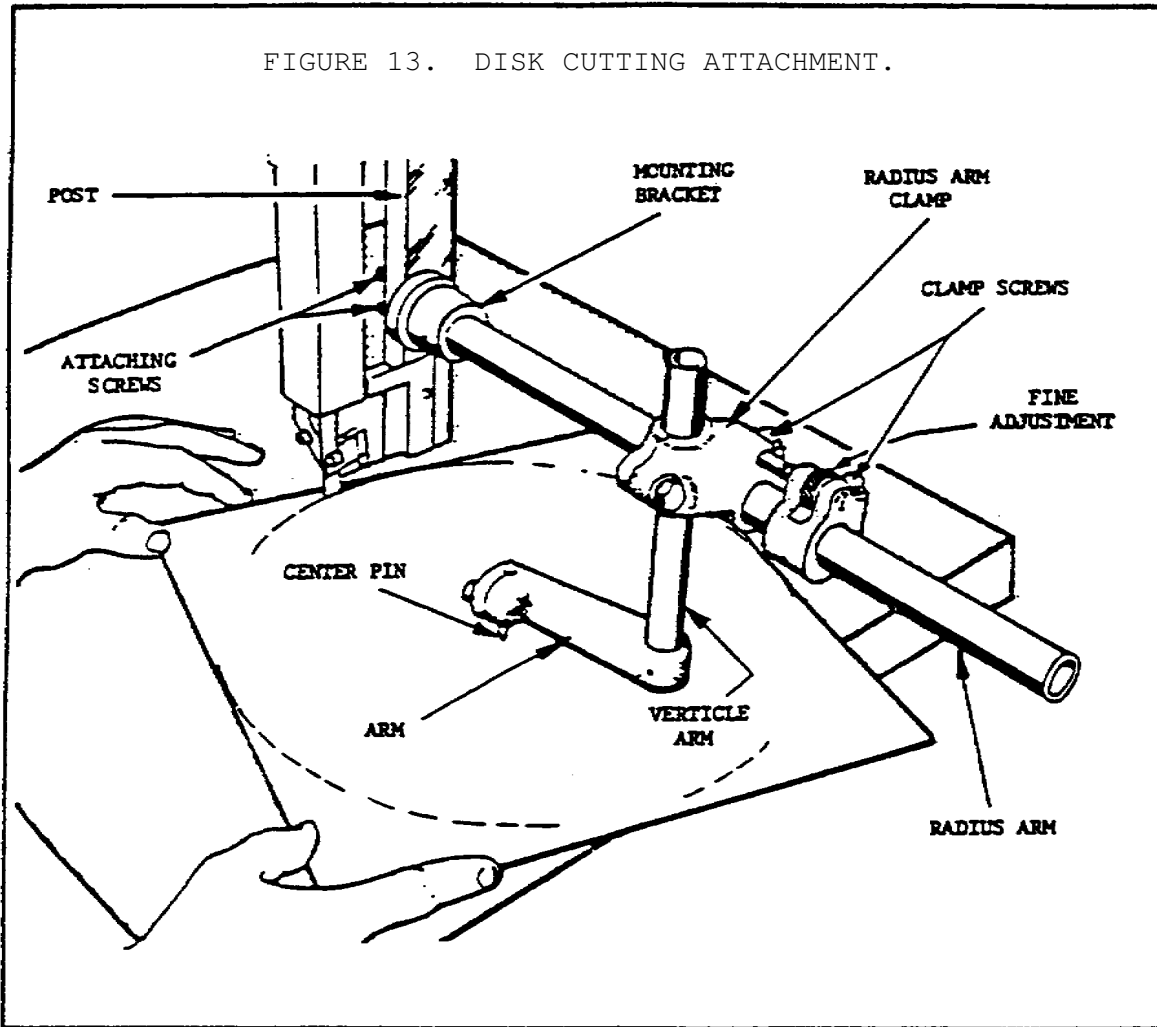

BANDSAW OPERATIONS - OD1646 - LESSON 1/TASK 1

TABLE 3. RECOMMENDED BAND TENSIONS.

Type of Saw Band	BAND WIDTH IN INCHES								
	1/16	3/32	1/8	3/16	1/4	3/8	1/2	5/8	3/4
Dart				10	12	18	28	45	45
Standard Carbon	1.5	2.5	3.5	5.5	7	12	14	26	31
Spring Temper				7	10.5	15	22	36	45
Friction							19		35
Knife Edge					7		16		28
Scallop Edge				7	10.5	15	22	28	45
Woodworking				7	10.5	15	22	36	45
Polishing Bands	1.5								
File Bands	3.5								

been correctly installed and tensioned, the tracking adjustment can be made by opening the wheel doors, pressing the start button, and observing how the band tracks. The tilt controls (figure 15 on the following page) can be used to adjust the upper wheel tilt until the band tracks properly. The band is tracking properly when the back edge of the band just touches the saw guide backup bearings. The band should ride near the center of the band wheel tire. When the band is tracking correctly, the tilt lock should be tightened.

CAUTION

Do not stand in front of bandsaw when operating machine or rotating upper wheel by hand to track blade.

(5) *Band Installation.* The procedures for installing a band differ slightly from model to model. The procedure for installing a band on model 2614-1 is considered typical and is described here. To install a band, the band wheel doors are opened. Then the bar which crosses the table saw slot just below the front edge of the table is unlocked and opened. The saw band guard is then removed from the post. Gloves are used when handling the band, as it is carefully placed over the wheels and between the saw guide inserts. The band guard is then replaced, and the bar is closed and locked over the table slot. Finally, the wheel doors must be closed. Blade tension should be set or adjusted. See TM 9-3419-227-10, page 10.

BANDSAW OPERATIONS - OD1646 - LESSON 1/TASK 1

(6) *Laying Out Workpieces.* When laying out workpieces for bandsaw operations, the size of the stock must be considered in relation to the clearance of the bandsaw machine column. For straight-line sawing, the clearance is easy to judge; however, for contour sawing of large size stock, the directions of cut must be carefully planned to prevent the stock from hitting the column. If a small section is to be cut from a large sheet of metal, the section should be roughly cut oversize from the sheet, and then carefully cut to the exact outline.

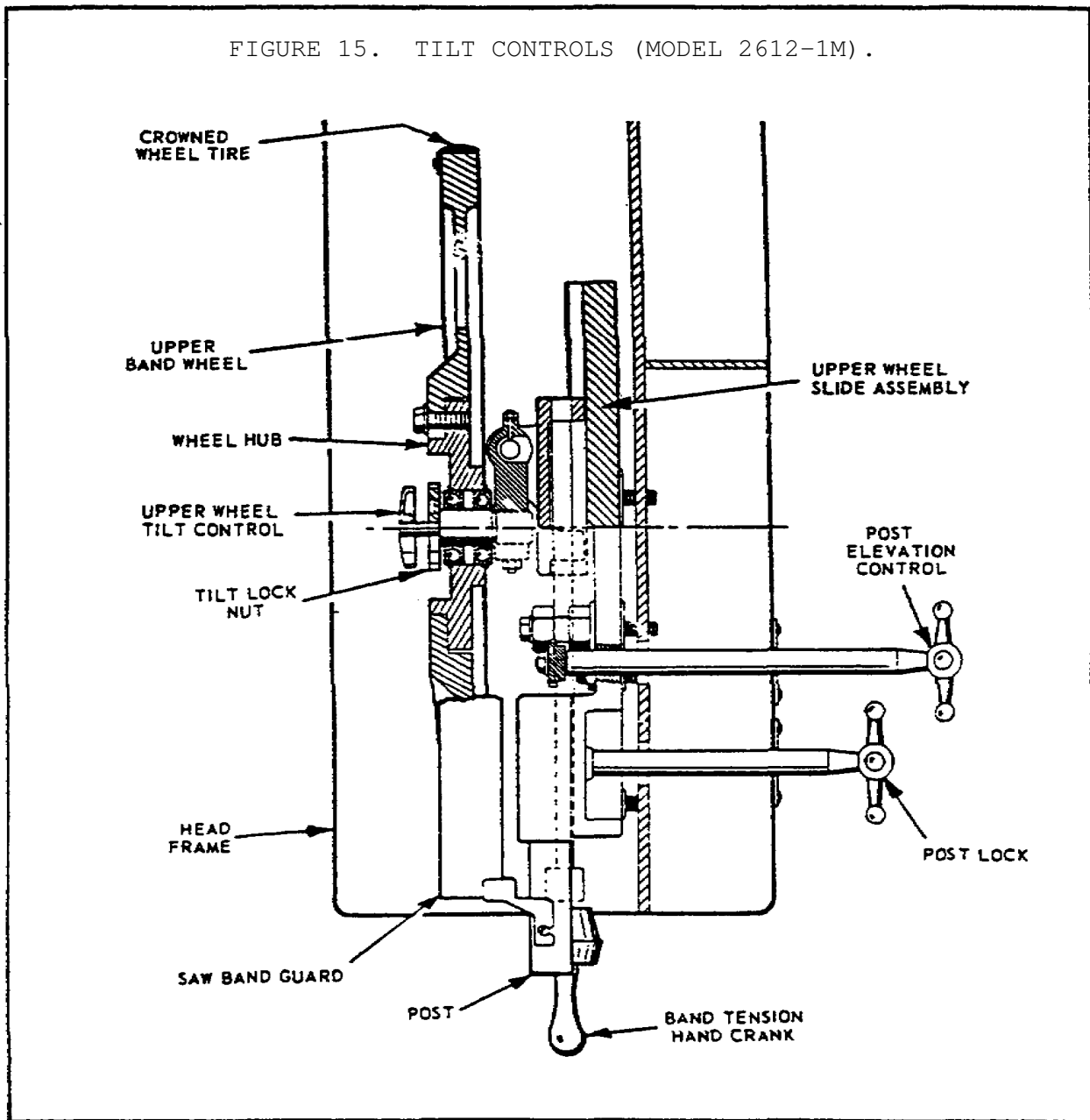

BANDSAW OPERATIONS - OD1646 - LESSON 1/TASK 1

(a) *Laying Out Pieces for Circular Sawing.* When a circle or disk is to be sawed using the disk cutting saw attachment, a compass or pair of dividers should be used to scribe a circle of the desired diameter on the stock. If possible, the circle should be scribed beginning at one edge of the stock so that the bandsaw blade may start the cut without preliminary sawing or notching. Next, a center hole should be drilled or center-punched into the disk to accept the center pin of the disk cutting attachment. The hole should be made only as deep and as large as needed for the center pin. Too large a hole will cause the center pin to fit loosely, which will result in an inaccurate cut.

(b) *Laying Out Pieces for Contour Sawing.* When an outline is to be cut that consists of more than two intersecting lines, the exact shape required should be scribed on the stock. When laying out the piece, save unnecessary cuts by taking advantage of straight, clean edges on the uncut stock. The bandsaw blade size should be selected according to the size needed to cut the smallest radius laid out on the workpiece. Then a twist drill equal to or greater in diameter than the width of the bandsaw blade must be selected. Using this drill, drill a hole in the solid stock in each corner of the pattern (figure 16 on the following page), making sure the holes fall completely within the section of material that will be removed. These holes are needed when sawing to permit the change of direction of the bandsaw blade from one cut to the other.

If an internal section is to be removed from the stock, and the edge must remain unbroken, lay out and drill a starting hole, using a drill larger in diameter than the width of the bandsaw blade. The bandsaw blade will be inserted through this hole before being welded into a band and installed on the bandsaw machine.

(7) *Bandsaw Speeds and Speed Controls.* The cutting speed of a bandsaw machine is the speed of the bandsaw blade as it passes the table, measured in feet per minute (fpm). Proper bandsaw speeds are important in conserving bandsaw blades. Too great a speed for the material being cut will cause abnormally rapid blade wear. Too slow a speed will result in inefficient production. In general, the harder the material, the slower the speed that should be selected. Conversely, the softer the

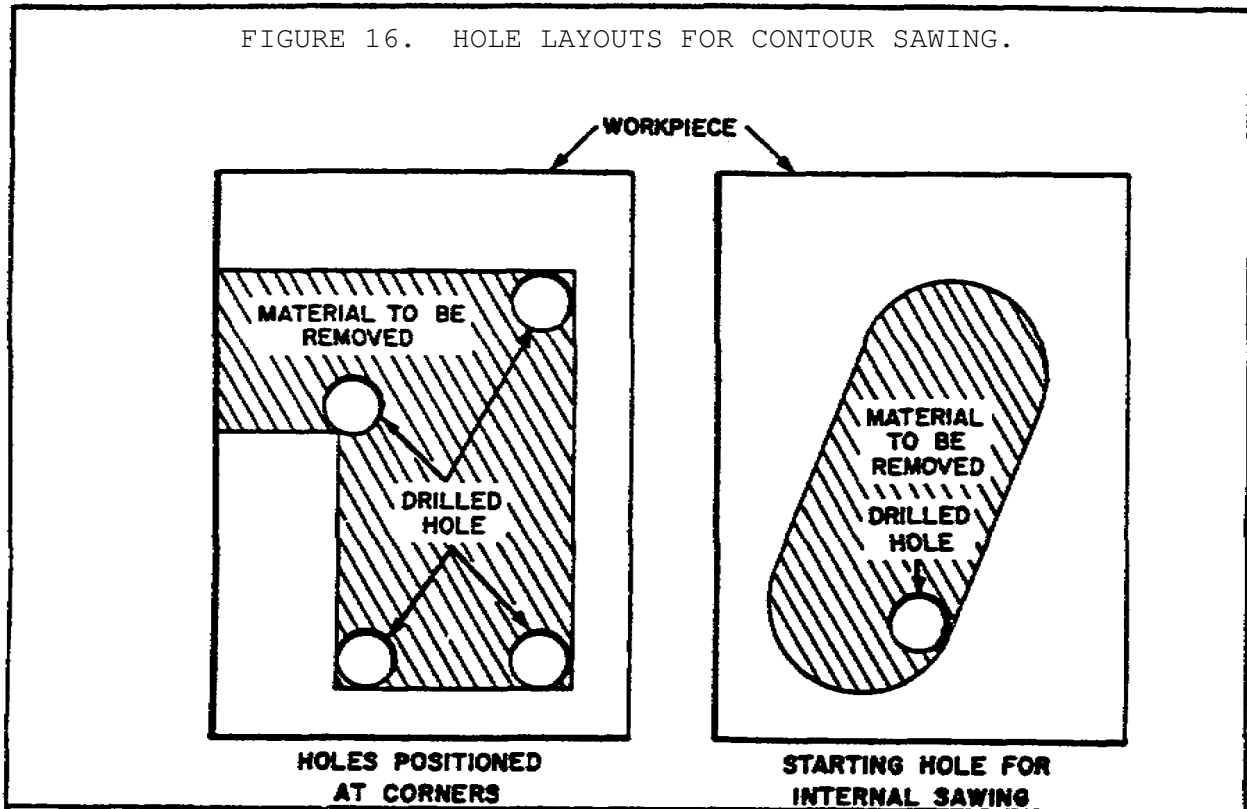

material, the faster the speed that should be selected. It is also true that the faster the speed, the finer the finish produced on the cut surface. This principle applies to light feeds in conjunction with fast speeds. Table 4 shows the recommended sawing speeds for different materials. In general, the faster speeds should be used to saw thin materials, and the slower speeds should be used for thick materials.

TABLE 4. BANDSAWING SPEEDS.

MATERIAL	BANDSAWING SPEED (FPM)
Aluminum.....	200 to 2,000
Bakelite.....	200 to 900
Brass, soft.....	175 to 300
Brass, hard.....	75 to 150
Brass, sheets.....	200 to 900
Bronze.....	75 to 150
Cast iron.....	50 to 100
Copper.....	115 to 175
Monel metal.....	50 to 100
Rubber, hard.....	150 to 250
Steel, alloy.....	50 to 100

TABLE 4. BANDSAWING SPEEDS
(CONTINUED).

MATERIAL	BANDSAWING SPEED (FPM)
Steel, high carbon....	50 to 100
Steel, high-speed.....	50 to 90
Steel, machine.....	75 to 175
Steel, sheet.....	150 to 200
Steel, stainless.....	50 to 75
Steel, tool.....	50 to 150

All metal cutting bandsaw machines have several cutting speeds which can be selected. Since the diameter of the drive wheel of the bandsaw machine establishes a fixed ratio between the motor or transmission speed in revolutions per minute to the blade speed in feet per minute, it is not necessary to convert revolutions per minute into feet per minute as with most other machine tool operations. The speeds are identified in feet per minute on the bandsaw machine speed selector controls. Some machines have a speed indicator with which a careful check of sawing speeds may be made when the machine is operating with or without a load.

(8) *Bandsaw Feeds.* The feed of a vertical bandsaw machine is the pressure applied to the bandsaw blade by the material being cut. With vertical bandsaw machines, the feed is applied to the workpiece instead of the saw blade. The workpiece may be hand fed or power fed, depending upon the operation to be performed. Cutting curves or special contours requires that the workpiece be fed into the bandsaw blade by hand.

(a) *Power Feeding.* The power feed on a bandsaw machine is operated by adjustable weights in the machine pedestal. The weights are connected by cables to one of the work holding attachments of the sawing machine to pull the workpiece against the bandsaw blade. To operate the power feed, the weights are raised by depressing a pedal and the cables are then fixed to the work holding attachment. When the pedal is released, the weights pull the piece into the blade.

(b) *General Rules for Feeding Workpieces.* A number of general rules apply to feeding workpieces on bandsaw machines. The feed should be light when starting a cut. The pressure can be increased

BANDSAW OPERATIONS - OD1646 - LESSON 1/TASK 1

after the cut is established. Also, hard materials require lighter feeds than softer materials. It is generally true that wider bandsaw blades will withstand greater pressures than narrow blades and can therefore be used with heavier feeds. When hard spots in the material being cut are encountered, the feed should be reduced until the spots are cut through. A light feed should be used when cutting curves; a heavier feed can be used for straight line cutting.

(9) *Coolants.* Most sawing machines used in military operations are dry-cutting machines; that is, they are not intended for use with liquid coolants. These bandsaw machines contain air pumps and hoses through which a jet of air is directed against the bandsaw blade and workpiece. The air acts as both a coolant and as a means of removing chips from the cutting area. The nozzle of the air hose should always be directed at the contact area of the blade and workpiece. The model 2614-1 bandsaw machine uses a mist coolant, designed to direct a fine mist stream of liquid coolant on the blade teeth and workpiece.

(10) *Safety Precautions.* When using or servicing the bandsaw machine, it is important to make safety a habit. Be sure to close the doors and replace all covers and safety guards before operating the machine. Wear safety glasses and wear gloves when handling the saw band. DO NOT, however, wear gloves when operating the machine. Set the saw guides as close to the work as possible. Close the band wheel cover before tensioning the band or starting the machine. Disconnect the electrical supply before removing panels or drive covers. Keep hands away from the moving saw band or blade. Before working on the machine, always check for these and other safety precautions in the technical manual (TM) appropriate to the bandsaw machine being operated or serviced.

b. *External Sawing.* External sawing is the process of using the bandsaw machine to make saw cuts that begin at the outer edge of the workpiece. These cuts may be straight-line, curved, or contoured.

(1) *Straight-Line Sawing.* In a typical example of straight-line sawing, a bandsaw blade of the desired pitch for the material to be cut is

BANDSAW OPERATIONS - OD1646 - LESSON 1/TASK 1

selected. The blade should be as wide as possible for straight-line sawing. Then the desired speed is set on the bandsaw machine. The workpiece is positioned at the desired angle in one of the bandsaw machine attachments. Then the cable is connected to the power feed mechanism (if the power feed is to be used). The bandsaw machine is then started. The workpiece is lightly fed into the blade to start the cut. Once the cut has been started, the feed can be increased. If the feed is being done by hand, the pressure applied to the workpiece by the operator can be varied to find the best cutting conditions.

Straight-line sawing is performed on the bandsaw machine by using one or a combination of several mechanisms or attachments: the miter guide attachment, with or without a power feed; the screw feed device, with or without the work holding jaw device; and the work holding jaw device with power feed and the angular blade guide attachment.

(a) *The Miter Guide Attachment.* The miter guide attachment on some machines can be connected to the power feed mechanism. On other machines, feeding must be done by hand when using the miter guide. The workpiece is clamped or hand-held against the miter guide attachment, and the workpiece and attachment are moved against the bandsaw blade. The miter guide assembly moves on a track parallel to the blade, thereby assuring a straight-line cut.

(b) *The Screw Feed Device.* The screw feed device is used to push the workpiece against the bandsaw blade in a direction parallel to the blade. The feed screw may be applied directly to the workpiece, or may be used to push the work holding jaw device in which the workpiece can be positioned at various angles.

(c) *The Work Holding Jaw Device.* The work holding jaw device (figure 17 on the following page) can be connected, on some machines, to the power feed to produce straight-line cuts.

(d) *The Angular Blade Guide Attachment.* The angular blade guide attachment is used for straight-line sawing when the workpiece cannot be cut in the normal manner because it is too large or too long to clear the column of the bandsaw machine frame.

BANDSAW OPERATIONS - OD1646 - LESSON 1/TASK 1

(2) *Curve Sawing.* Curve sawing is performed either by using the disk cutting saw attachment or by hand guiding the workpiece.

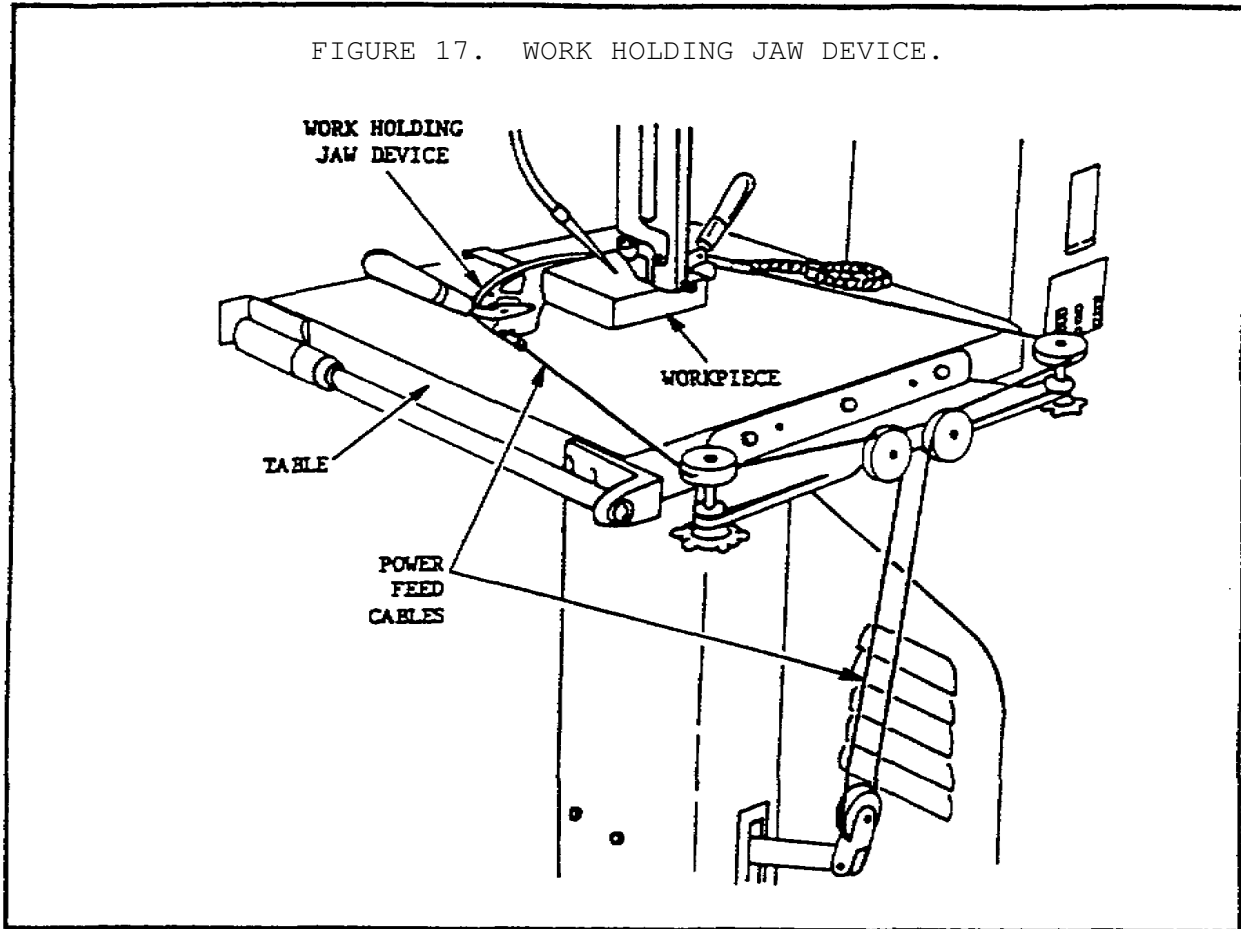

(a) *Selecting the Blade.* Care must be taken to select a bandsaw blade of the proper width for the radius or curve to be cut. If a blade is too wide for the radius, the heel of the blade will press against the outer edge of the kerf (figure 18 on the following page). When the heel contacts this edge, any further twisting of the workpiece in an attempt to cut a sharper radius will twist the bandsaw blade without cutting a sharper radius.

(b) *Cutting the Curve.* On curve cutting, less pressure must be applied to the workpiece than on straight-line cutting. The smaller the curve, the more care must be exercised. It should be understood that when any material is cut with a flexible bandsaw blade, the blade deflects to the rear in proportion to the amount of pressure applied to the workpiece. This deflection,

referred to as "drag," will not affect a straight-line cut because the sides of the blade remain parallel to the cut. However, when curves are cut on the bandsaw machine, the drag will cause a "belly" in the cut section. To reduce the belly to a minimum, the drag must be reduced to a minimum, and this can only be done by reducing the pressure applied in feeding the workpiece into the blade.

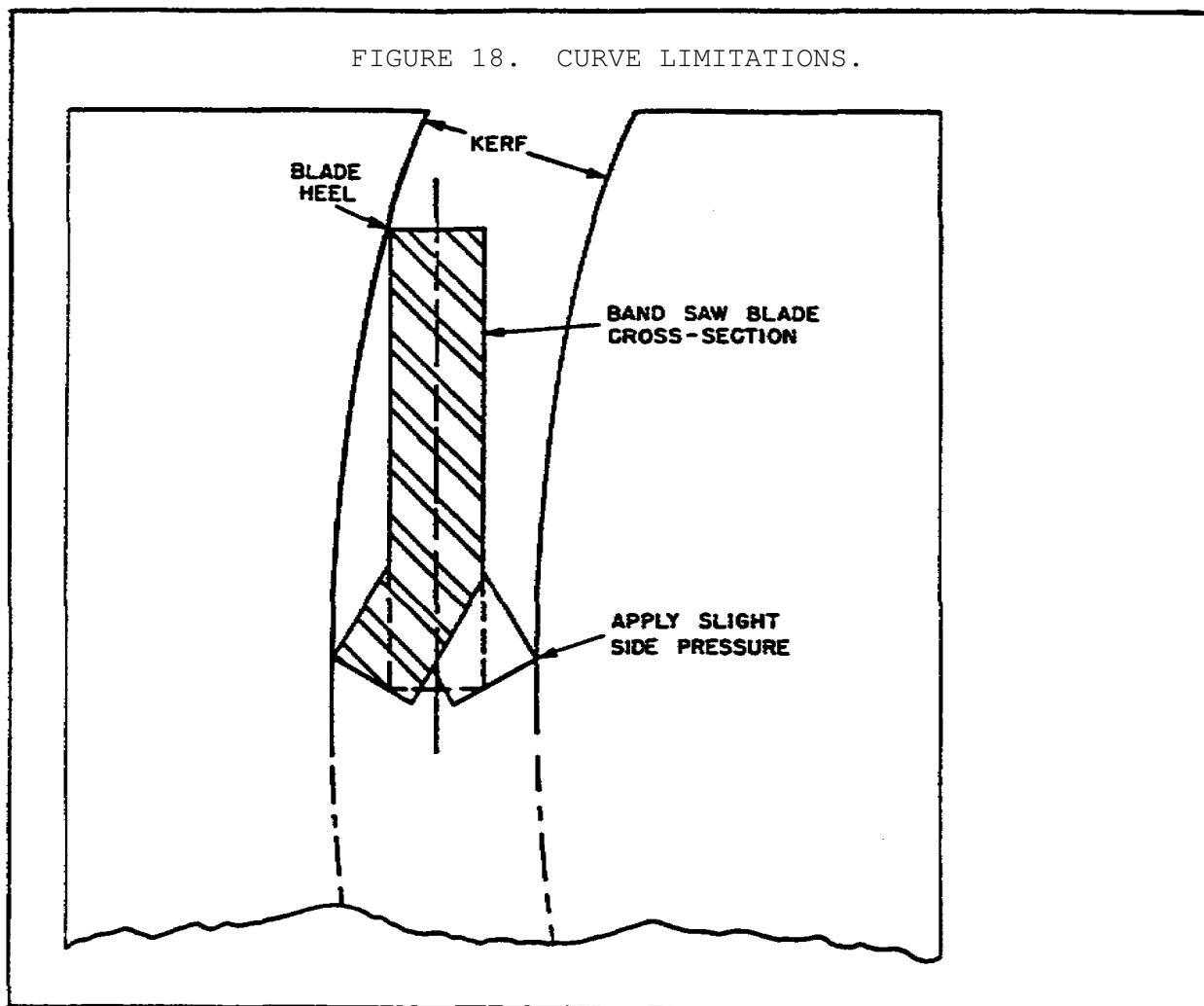

(c) *Curve Sawing at an Angle.* When sawing at an angle with the table tilted, a curve or radius will be shaped like a cone section, with a larger radius on one workpiece surface, and a smaller radius on the other workpiece surface. It is very important when cutting at angles that the smaller of the two radii be used to determine the bandsaw blade size. Figure 19 (on the following page) shows a chart of recommended bandsaw widths for minimum radii to be cut. The recommendations on

this radii chart are based on sawing relatively thin stock. Use a narrower blade than recommended when sawing stock more than one inch thick.

FIGURE 19. MINIMUM RADII CHART.

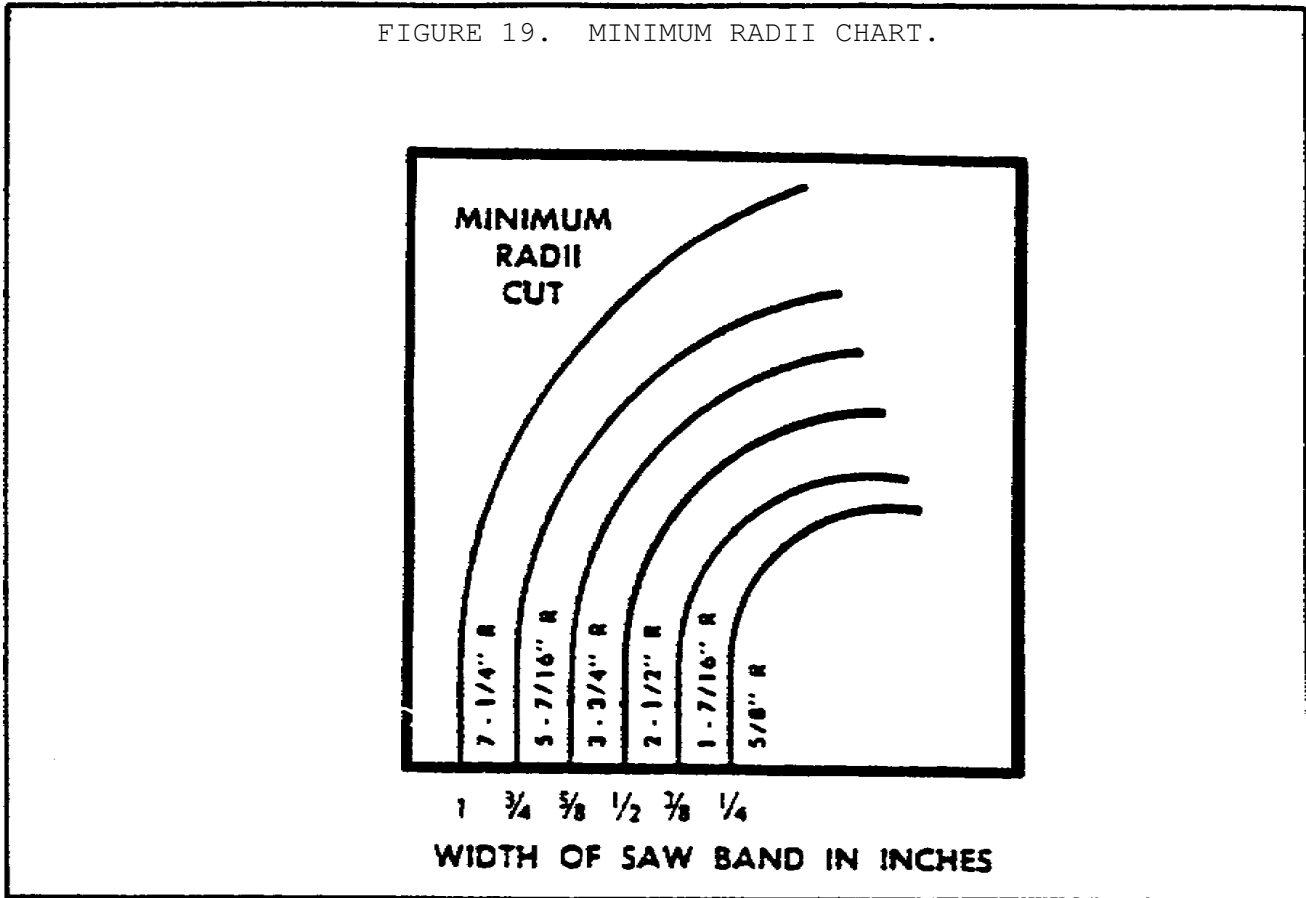

(3) *Contour Sawing.* Contour sawing is the process of cutting shapes in which the direction of the cut must be changed at intervals. Holes larger in diameter than the width of the saw blade must be drilled at each corner where a change of direction of the bandsaw blade will occur. After the shape is cut either by sawing away from the hole or sawing toward the hole, and the slug or waste material has been removed, the corners should be finished by filing or notching. The bandsaw blade should not be used for these operations because the blade will bow and cut unevenly.

(a) *Sawing Away From the Hole.* To saw away from the hole on a line next to the hole, the bandsaw blade must cut away from the center of the hole, or the blade will bow and cause a belly in the cut. Two methods can be used to accomplish this. In the first method, to start the cut, a curve is cut outward from the hole to meet the

layout line, leaving a piece of excess metal which can be removed later by filing (figure 20). In the second method, a section of metal is notched out with a saw blade by several short cuts to give the blade clearance for starting the cut along the layout line (figure 21).

FIGURE 20. SAWING AWAY FROM THE HOLE - METHOD 1.

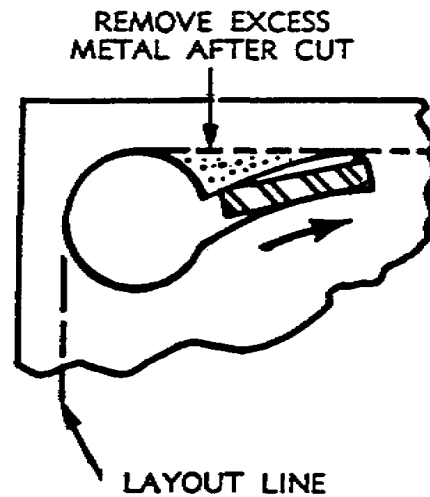
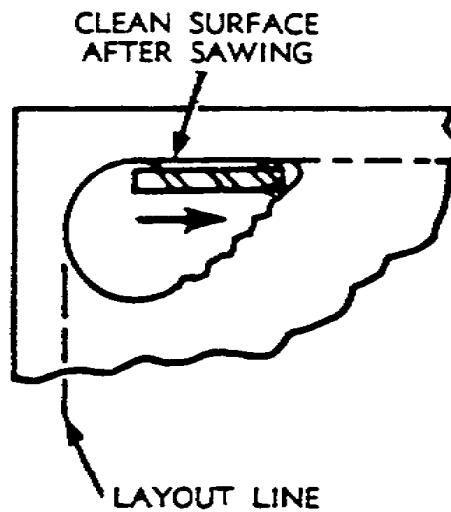

FIGURE 21. SAWING AWAY FROM THE HOLE - METHOD 2.



BANDSAW OPERATIONS - OD1646 - LESSON 1/TASK 1

(b) *Sawing Toward the Hole.* Sawing toward the hole is properly accomplished in two cuts. The first of these cuts is shown in figure 22 and the second is shown in figure 23.

FIGURE 22. SAWING TOWARD THE HOLE - FIRST CUT.

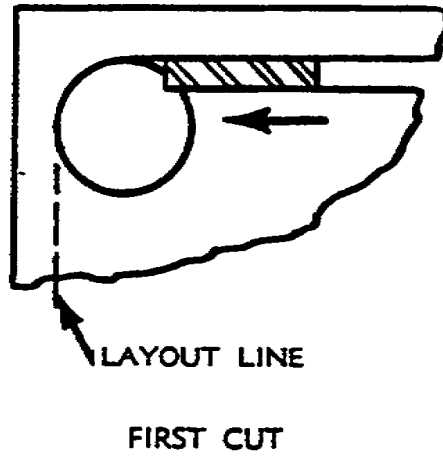
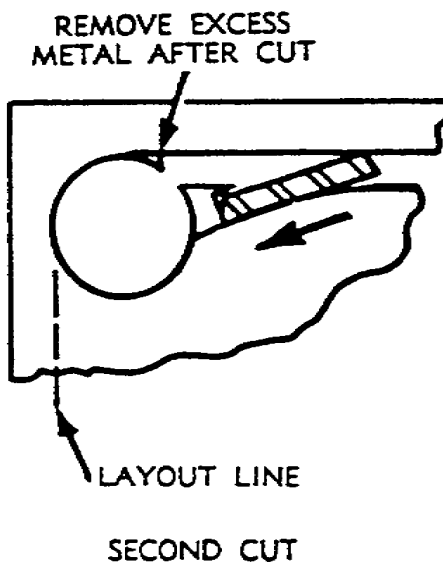

FIGURE 23. SAWING TOWARD THE HOLE - SECOND CUT.



BANDSAW OPERATIONS - OD1646 - LESSON 1/TASK 1

c. *Internal Sawing.* Internal sawing is performed in the same way as contour sawing, except that the bandsaw blade cannot start cutting from the edge of the workpiece but must start cutting from a drilled hole in the workpiece (refer to figure 16 on page 21). With the pattern laid out on the workpiece and with the starting hole drilled, an unwelded bandsaw blade of the proper length is inserted through the starting hole. Then the two ends of the blade are brought together at the butt welder of the bandsaw machine. The blade is then welded into a continuous band. The bandsaw blade is then installed onto the bandsaw machine. When the sawing operation is completed, the bandsaw blade is cut so that it can be removed from the workpiece.

d. *Cutting and Welding the Band.* When installing a bandsaw blade, or when cutting and rewelding the blade for internal sawing operations, the blade and the welder must first be properly prepared; then the blade can be welded. Follow this procedure to cut and weld a bandsaw blade.

NOTE

In the description that follows, the model 2612-1M bandsaw machine with integral welder is used as an example. The procedures for welding a bandsaw blade are similar for all models.

(1) *General.* The butt welder on the model 2612-1M bandsaw machine is capable of welding 3/4 inch wide by .032 gage carbon or Dart saw bands. The two clamping jaws of the welder hold the butted band ends together. When the welding switch lever is pressed, an electric current is induced through the butted ends of the blade, creating enough heat to soften the metal and join the ends. Pressing the welding lever (figure 24 on the following page) also releases a spring which causes the jaws to force the band ends together. When the movable jaw has moved .065 inches toward the stationary jaw, the electric current is automatically cut off. The spring force on the jaws is released when the welding lever is released.

FIGURE 24. WELDER CONTROLS.

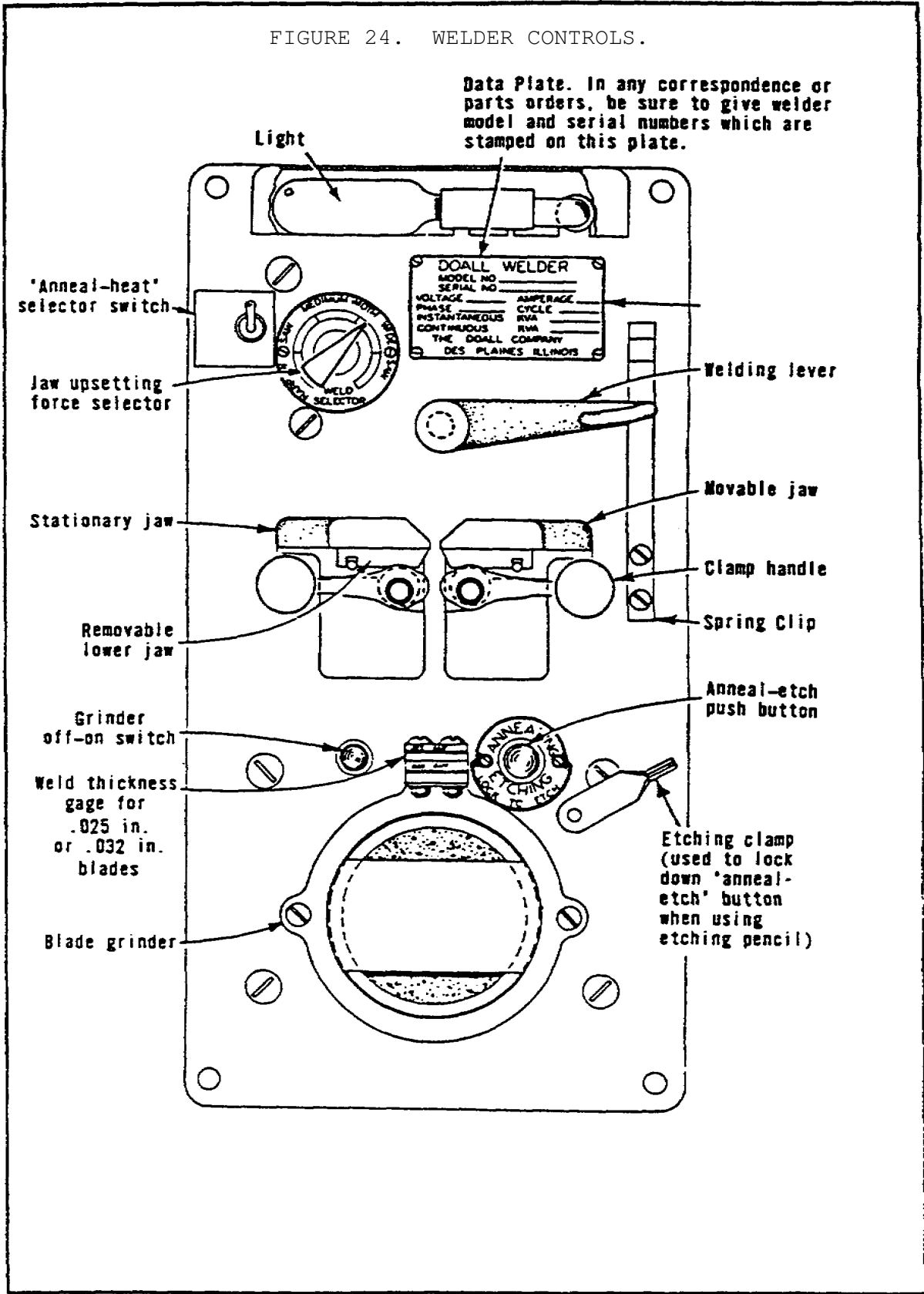

BANDSAW OPERATIONS - OD1646 - LESSON 1/TASK 1

(2) *Preparing the Blade.* First, the saw blade must be cut to length. Using a blade shear will ensure that the blade ends are flat, square, and smooth. If snips have been used to cut the blade, the ends must be squared before welding. This is done by grinding the ends of the blade. Both ends of the saw blade should be ground in one operation. Holding the ends so that the teeth point in opposite directions during grinding will ensure that the two ends will match perfectly when turned over, regardless of the angle of grinding. Then blade ends must then be carefully cleaned. The part of each blade that comes into contact with the welder jaws must be free of all dirt or oil. Any dirt or oil on the blade or welder jaws will prevent good electrical contact.

(3) *Preparing the Welder.* First, clean the welder jaws. On the model 2612-1M bandsaw machine, the integral butt welder has a jaw upset force selector (refer to figure 24 on the previous page), located directly above the stationary jaw. The jaw upset force selector provides a variable control since wider saw bands need greater upsetting force between the jaws than narrow bands, and since too much force on small bands will cause climbing or overlapping. In preparing to make a weld, the jaw upsetting force selector control should be set to the correct position for the width of the saw blade being welded.

(4) *Saw Blade Alignment Before Welding.* Before making the weld, the saw blade ends must be aligned so that the blade will be straight after welding. If internal sawing is to be done, the blade is inserted through the starting hole in the work. Then the ends of the saw blade are brought to the welder to be clamped into the jaws. Align the blade using these steps:

(a) Insert the saw blade between the jaws with the back of the blade against the back of the jaws, lining up the blade so that it will be straight after welding.

(b) The blade ends should meet in the center of the jaw gap without any offset either in thickness or across the width (figure 25 on the following page). If the ends are clamped in an offset manner, an overlapping weld will result. This type of weld will have to be ground too much, resulting in a weak weld.

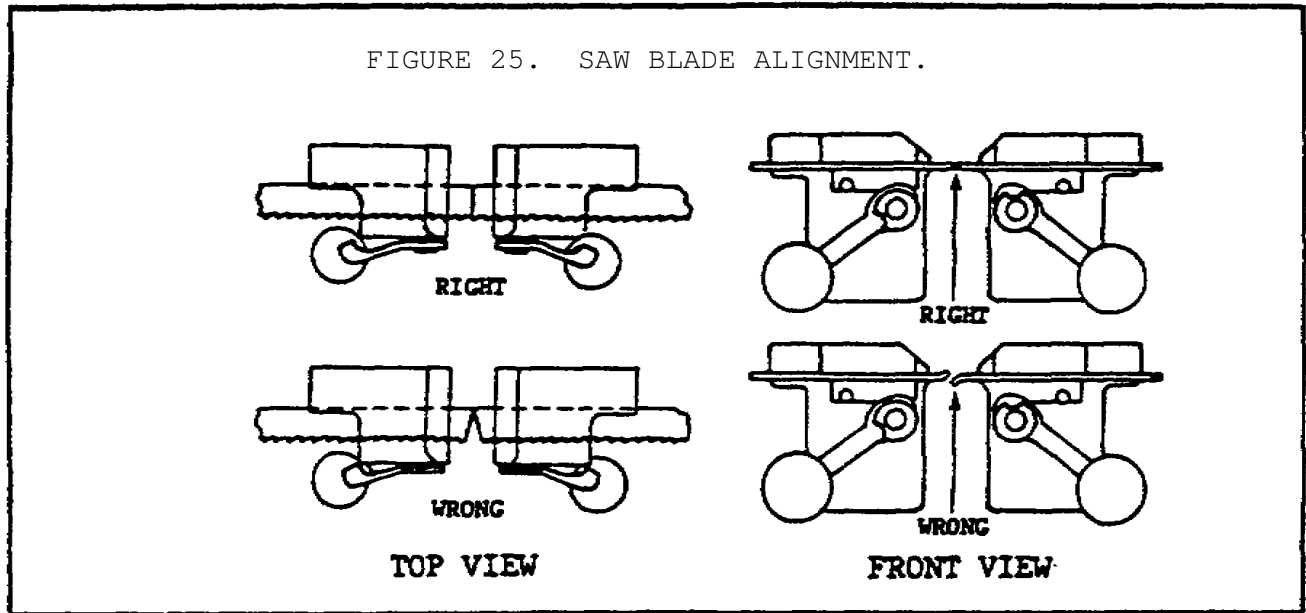

(c) If the contact across the width is not complete when the ends are clamped in the jaws, remove one end and recut it. A misaligned joint will cause an incomplete weld.

(d) After the blade ends are lined up, clamp them securely, but not so tightly as to harm the set, between the welder jaws.

(5) *Making the Weld.* After the blade ends have been aligned, press and hold down the weld lever (refer to figure 24 on page 32) to make the weld. The lever should be held down until the weld has cooled. The stationary jaw clamp should be released before the weld lever is released. This will prevent scoring the welder jaw surface. Then release the weld lever. When the lever is released, the butt welder mechanism and electrical switches will be automatically recocked, and the band will be ready to be annealed. Remove the welded saw band. Two general statements about welding the band should be noted:

(a) Cut out the old weld as each new weld is made. Since only one weld is recommended in a saw band, use the blade shear to cut away small portions of the ends of the old weld. Since the welding operation uses up no more than 1/16 inch of the band, it will not shorten the band appreciably, even after several welds have been made. Starting with a full size saw band, approximately three to four inches of band can be used in making welds

before the band will be too short to fit over the machine wheels.

(b) If it is found, after making the weld, that the teeth of the band point in the wrong direction, it can be reversed by turning the band inside out. However, this cannot be done when the band is welded through a piece of material for internal sawing. In this case, the saw band must be cut and welded.

(6) *Cleaning Up After Welding.* It is important that the welder jaws be kept clean at all times. The jaws and inserts must be wiped and/or scraped clean after every weld. Doing this will maintain the strength and fatigue characteristics of the band by holding proper alignment, preventing flash from becoming embedded in the band, and preventing shorts or poor electrical contact.

(7) *Inspecting the Weld.* When the band is removed from the welder, it should be inspected carefully. The color of the upset material around the weld should be blue-gray, and of equal intensity throughout. The spacing of the teeth should be uniform, and the weld should be located in the center of the gullet. Major jaw misalignment is easily noted at this time from the weld appearance. Figure 26 shows several types of defective welds. If a weld is imperfect, some of

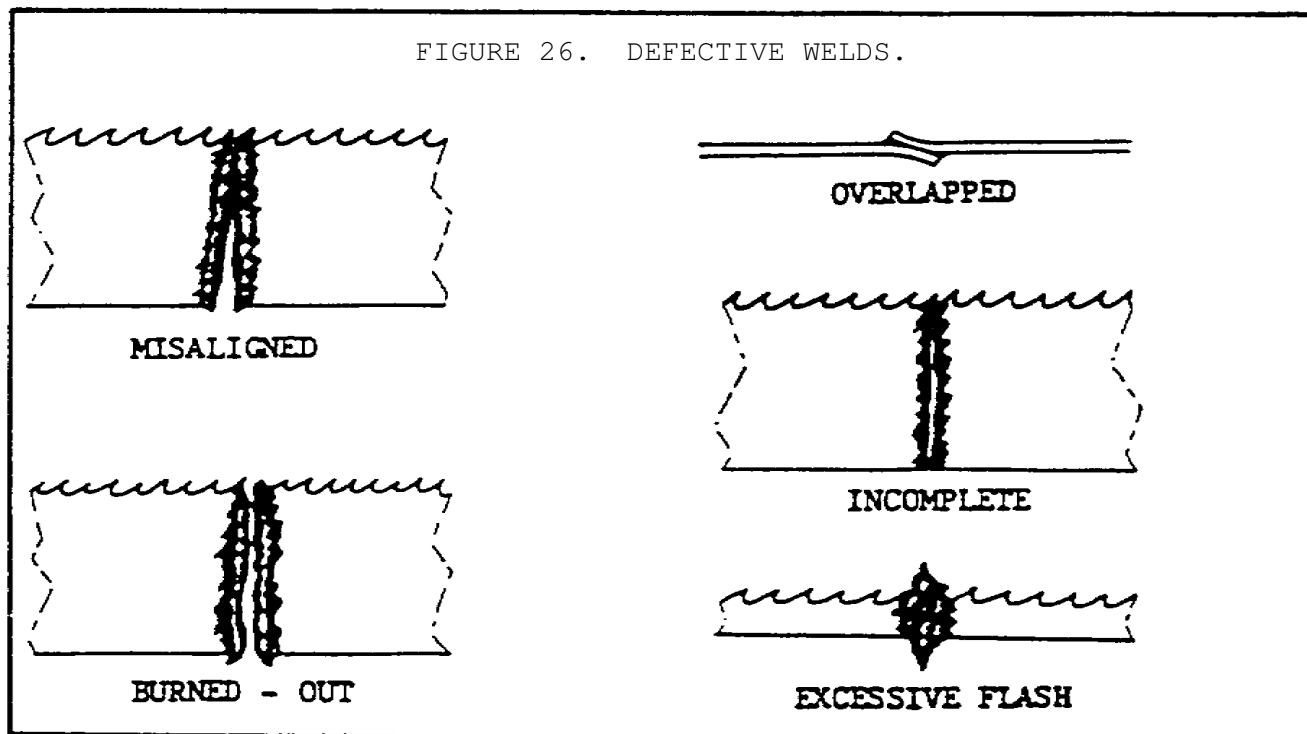

BANDSAW OPERATIONS - OD1646 - LESSON 1/TASK 1

the possible causes can be found, if needed, in TM 9-3419-228-10, beginning on page 46 (or in the troubleshooting section of the TM for the welder being used).

(8) *Grinding the Welded Band.* After welding, the band must be dressed to remove excess metal or flash from the weld. Grind the welded area down to the same thickness as the rest of the band. The weld should be ground with the teeth facing out (figure 27). Care must be taken during grinding so as not to hit the teeth, not to grind deeper than the thickness of the band, and not to burn or overheat the weld area. The weld should pass freely through the gage above the grinding wheel.

CAUTION

Use care in handling the band; the weld is brittle because it has not yet been annealed.

FIGURE 27. GRINDING THE WELD.

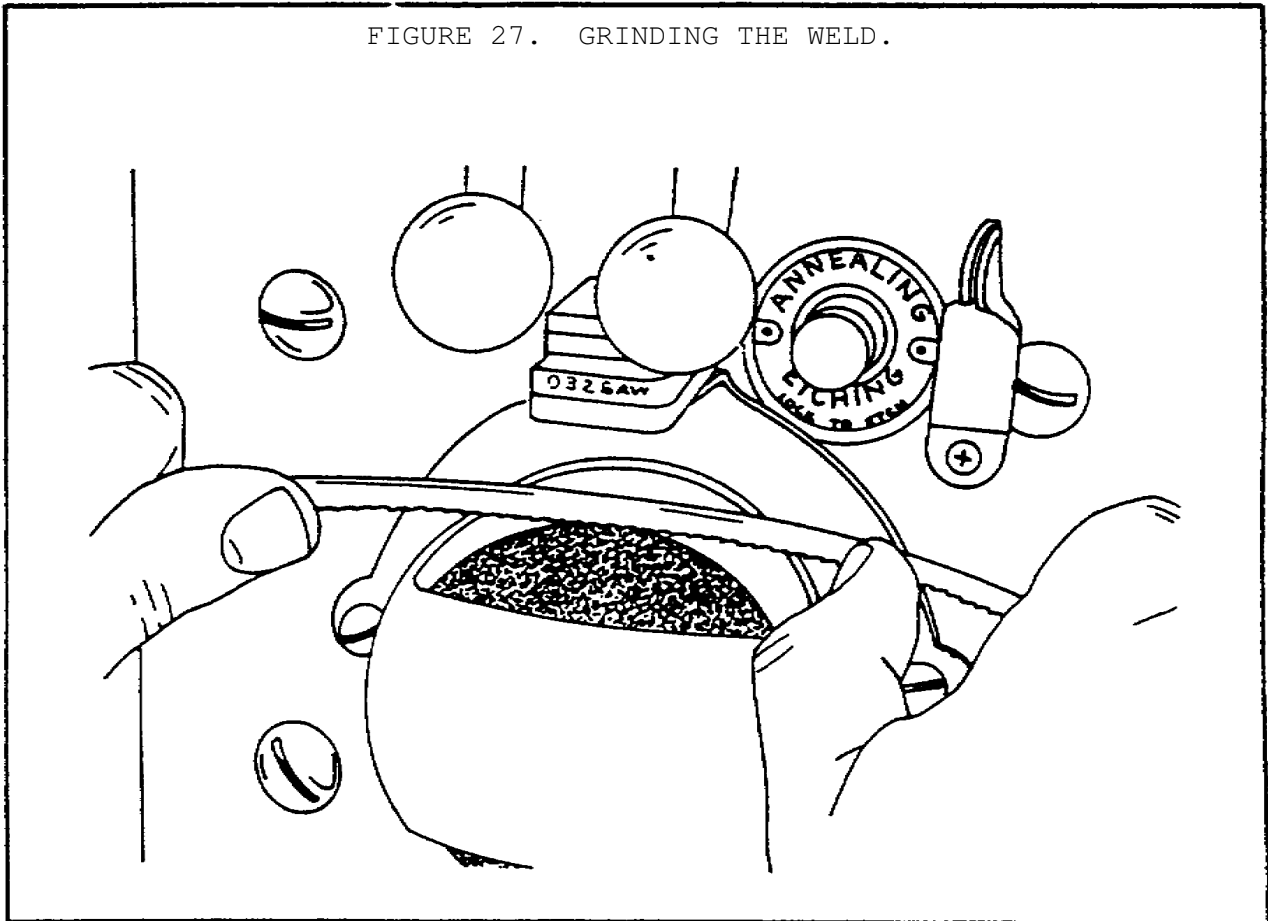

BANDSAW OPERATIONS - OD1646 - LESSON 1/TASK 1

(9) *Annealing the Welded Band.* Directly above the grinding wheel is the annealing pushbutton. When the band is heated up in the welding and grinding process, the steel at the point of the weld air-hardens and is brittle. Therefore, it is necessary to anneal the weld by reheating it and allowing it to cool slowly. This returns the band to an approximation of its original temper. Use these steps to anneal the weld:

(a) Clean the welder jaws.

(b) Press the spring clip behind the weld lever, and move the lever up all the way.

(c) Clamp the band just back of the teeth.

(d) Set the ANNEAL HEAT selector switch (refer to figure 24 on page 32) at either the 1/16 inch to 1/2 inch or the 5/8 inch to 3/4 inch position, according to the width of the blade being annealed.

(e) The next step in the annealing process depends on the type of blade being annealed. It is very important that this step be performed carefully:

1 *Carbon Blades.* If a carbon blade is being annealed, press and jog the anneal switch pushbutton until the weld is a dull cherry to cherry red in color. Then allow the blade to cool slowly by decreasing the jogging frequency.

2 *Dart Blades.* For a Dart blade, heat the blade slowly until the weld becomes a deep blue color. Continue to heat by jogging the anneal switch pushbutton until the width of the blue color is one-half the length of the band exposed between the jaws. Do not overheat or the temper of the band adjacent to the weld will be damaged. Cool quickly by releasing the button.

e. *General Filing Operations.* Filing operations are performed on the bandsaw machine using a band file and the band file attachment. As with sawing operations, the quality of filing and the economical wear of the band file depend upon proper selection of files and filing speeds for different materials and conditions.

BANDSAW OPERATIONS - OD1646 - LESSON 1/TASK 1

(1) *Band File Attachment.* Most bandsaw machines have a band file attachment (figure 28) to permit the use of band files on the machine. A typical band file attachment consists of a band file guide and upper and lower guide supports. These supports attach to the frame and post of the bandsaw machine to provide a rigid track upon which the band file can ride. A special filing filler plate is provided to adapt the table slot to the extra width and depth required for the band file and the file band guide. A special filing filler plate is provided to adapt the table slot to the extra width and depth required for the band file and the file band guide. Most band file attachments have either adjustable guides and guide supports, or two or more file band guides, so that different width file bands can be accommodated.

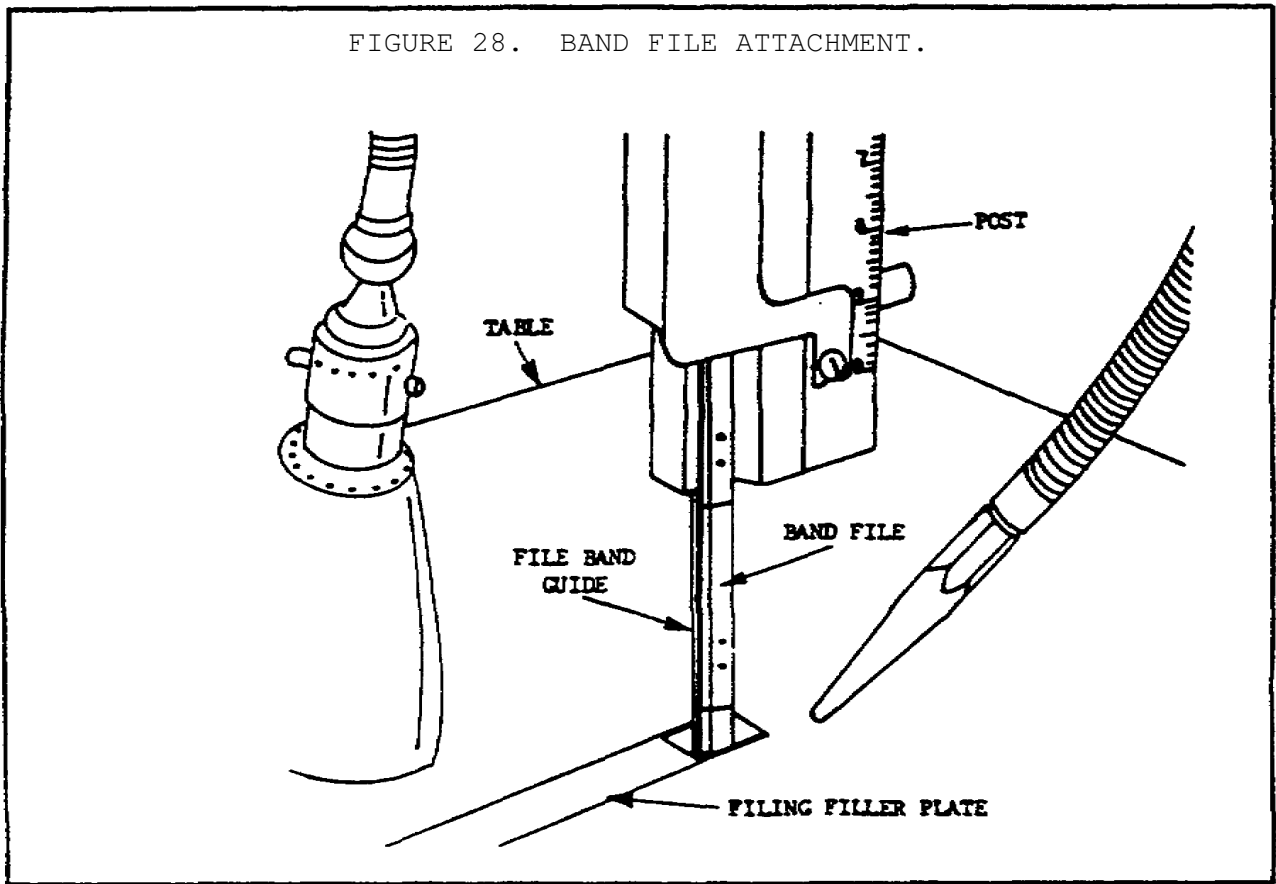

(2) *File Bands.* The bandsaw machine is adapted for filing by use of the band file attachment. A band file is fitted over the drive and idler wheels in place of the bandsaw blade. Band files (figure 29 on the following page) consist of many interlocking file segments that are riveted to flexible steel bands. These bands are attached to each other, end to end, to form a continuous band. The file segments are attached to the steel bands

in such a way that they will form a continuous filing surface when held in a straight line, but will separate from each other as they move around the idler and drive wheels. The band file attachment provides a support behind the file above the table, so that the band file cannot be forced backward by the pressure of the workpiece as it is filed.

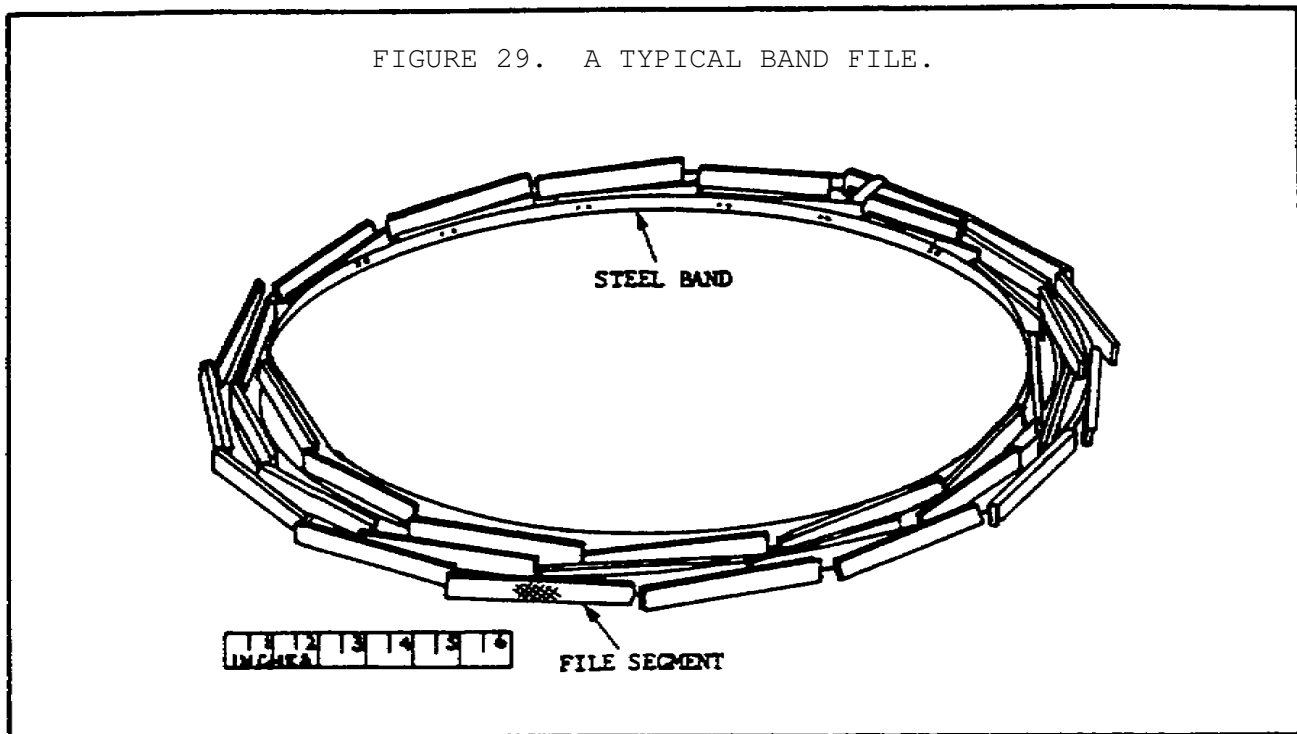

(a) *Cut of File Teeth.* Most files are classed as single-cut or double-cut files according to the kind of teeth. Single-cut files have rows of parallel teeth extending across the face of the file at an angle. Double-cut files have two rows of parallel teeth which cross each other. The first row, usually cut at about a 45° angle, is coarser and deeper than the second row which is generally cut at an angle of from 70° to 80° . Band files are always of the double-cut type. Double cut files of medium pitch are called bastard-cut files. These files usually have between 12 and 24 teeth per inch. Bastard-cut band files are commonly used for filing steel and other hard metals on the bandsaw machine. Short angle-cut files are double-cut files in which the two rows of teeth have been cut at shorter angles than those of the bastard-cut file. Short angle-cut files are usually coarse pitch, having 10 or 11 teeth per

BANDSAW OPERATIONS - OD1646 - LESSON 1/TASK 1

inch. Short angle-cut band files are commonly used for filing soft metals on the bandsaw machine.

(b) *Band File Shapes.* Band files are manufactured in flat and oval shapes. Flat band files are used for most filing jobs. Oval band files have a curved face, and are used for filing inside curves and contours. Band files are made in 1/4, 3/8, and 1/2 inch widths.

(c) *Selection of Band Files.* Band files should be chosen on the basis of workpiece thickness and the kind of material to be filed. In general, as the workpiece becomes thicker, the file should be coarser. This is because larger total chip accumulation from thick pieces requires additional space for the chips between the teeth. On thin sheet metal, a fine pitch file is required to prevent chatter. Narrower pitch files are used for tough carbon and alloy steels; wider and coarser pitch files are used for softer, more free-cutting materials such as cast iron and nonferrous metals. Table 5 provides a guide for selecting the proper file for specific materials. If sheet metal is to be filed, a finer tooth file should be used, if necessary, to reduce chatter and produce a better finish on the workpiece.

TABLE 5. SELECTION OF BAND FILES.

MATERIAL	TEETH CUT OF TEETH	PER INCH
Aluminum	Short angle- or bastard-cut	10-12
Brass	Short angle- or bastard-cut	10-12
Bronze	Short angle- or bastard-cut	10-12
Cast iron	Short angle- or bastard-cut	10-12
Copper	Short angle- or bastard-cut	10-12
Fiber	Short angle- or bastard cut	10-12
Magnesium	Short angle- or bastard cut	10-12
Steel, alloy	Bastard-cut	14-24
Steel, machine	Bastard-cut	14-16
Steel, tool	Bastard-cut	14-24

(d) *Care and Cleaning of Band Files.* The particles of metal removed by the file often lodge in the file teeth, reducing the cutting efficiency of the file and affecting the quality of the finish. If hard metal particles are lodged in the

file teeth, they may scratch the workpiece. When steel is to be filed, chalk can be rubbed into the file before filing; the chalk will reduce the tendency for hard particles to adhere to the file. The file should be cleaned often, using a stiff brush or a file card. The brush should be moved in the direction of each cut of the file to dislodge all particles hidden between the teeth.

(3) *Band Filing Speed.* Band files should be run at relatively slow speeds as compared to speeds used for bandsawing. In general, the best filing speeds are between 80 and 150 feet per minute (fpm). Table 6 lists the recommended filing speeds for band filing. Note that, in general, the slower speeds are used for filing harder metals, and the faster speeds are used for filing softer metals.

TABLE 6. BAND FILING SPEEDS.

MATERIAL	BAND FILING SPEED (FPM)
Aluminum.....	75 to 175
Brass.....	115 to 260
Bronze.....	75 to 115
Cast iron.....	50 to 115
Copper.....	115 to 260
Fiber.....	115 to 175
Magnesium.....	75 to 175
Steel, alloy...	50 to 115
Steel, machine.	75 to 175
Steel, tool....	50 to 75

(4) *Band Filing Feeds.* Work pressure on the band file should not be excessive. Medium pressure applied against the band file moving at the proper speed will produce curled chips which will not clog the file. Heavy pressure will cause clogging and can cause the file to break or the machine to stall. A light pressure should be used for finish filing, with a slow, sideways motion that will not leave vertical file marks on the workpiece.

BANDSAW OPERATIONS - OD1646 - LESSON 1/TASK 1

NOTE

The procedures used for band filing using bandsaw machine model 2612-1M are presented here as an example of band filing procedures. Band filing procedures are similar for all bandsaw machine models.

(5) *Setting Up the Machine for Filing.* To set up the model 2612-1M bandsaw machine for either internal or external filing, perform these steps:

(a) If the machine is set up for sawing, remove the saw band.

(b) Remove the table center disk and post saw band guard.

(c) Remove the saw guides from the machine.

(d) Mount the file guide support on the lower keeper block, making sure the proper width of slot for the file band is being used.

(e) Lower the upper post to the proper work thickness. This thickness should not exceed two inches for a 1/4 inch file band and four inches for 3/8 and 1/2 inch bands.

(f) Install the upper file guide (figure 30 on the following page), locking it firmly to the post with the knurled thumb screws.

(g) Install the special table center disk for filing.

(6) *Joining the File Band.* To join the file band, take one end of the file band in each hand, with the yellow painted end (figure 31 on the following page) in the left hand. Hold the file ends at right angles with the filing surface up. Depress the tip of the spring steel band held in the right hand with the lock rivet of the yellow segment held in the left hand. Allow the rivet head to slip into the slotted hole. Slide the rivet head into the small end of the slot. Straighten the file band, allowing the spring steel end to snap over the dowel. Make sure that the ends of the band are flush before running the band on the machine.

FIGURE 30. SETTING UP FOR FILING.

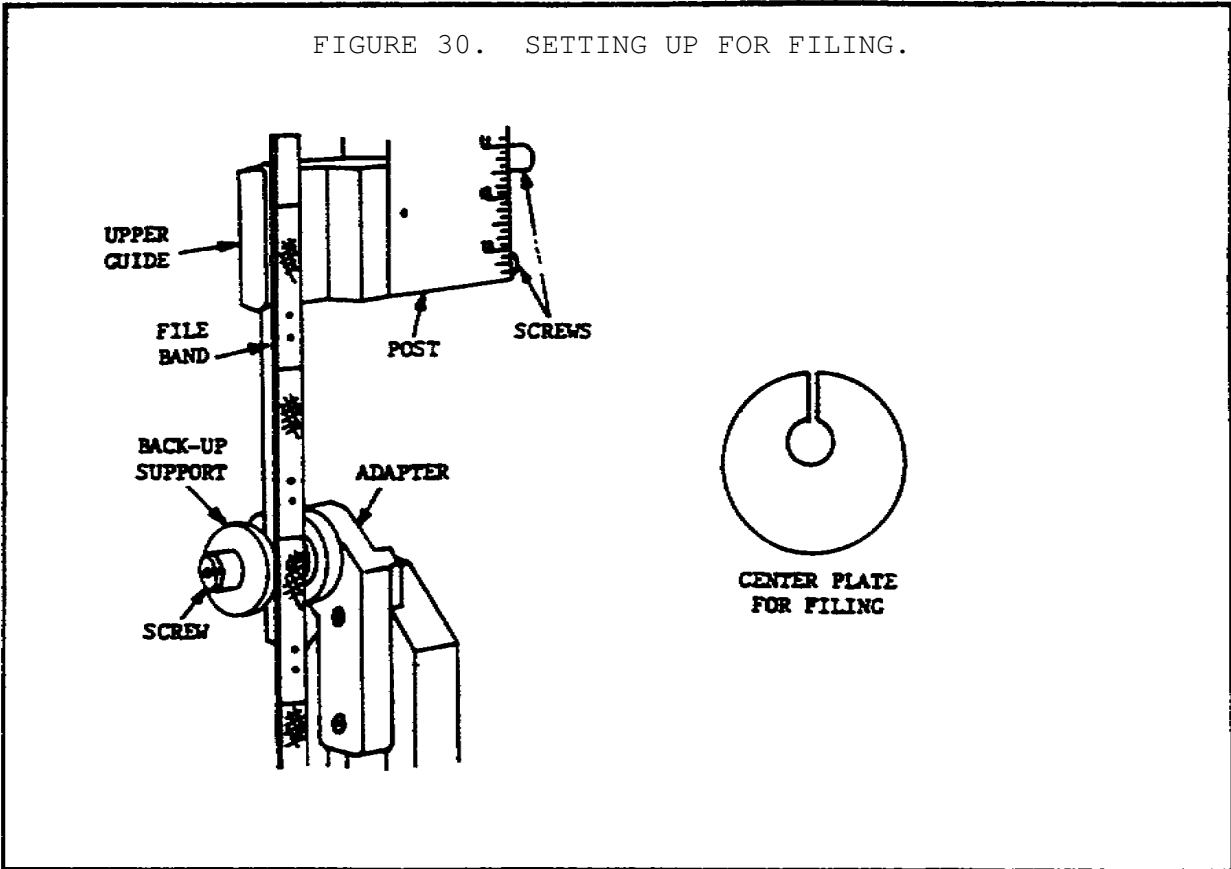
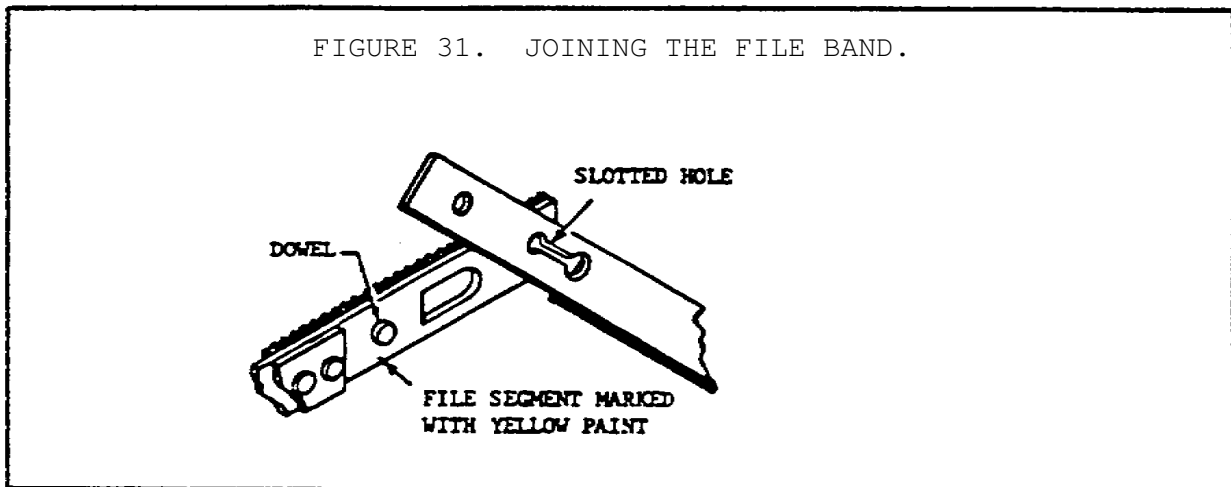

FIGURE 31. JOINING THE FILE BAND.



(7) *Tracking and Tensioning the File Band.* The file bands are aligned on the wheels in the same way as is used in tracking the saw bands, described in paragraph 4a(4) beginning on page 17. The band can be made to run on the crown of the wheel by tilting the upper wheel with the tilt control. When properly tracked, the file band should run freely in the file guide channel. The tension of the file band should be adjusted to the same

BANDSAW OPERATIONS - OD1646 - LESSON 1/TASK 1

tension as that used for a 1/8 inch wide carbon saw band. Too much tension will cause the file segment rivets to break when heavy filing pressure is applied. While it might seem, at first, that better filing results are obtained with excess tightening of the file band, this will not be the case in the long run. Most accurate filing can be obtained with the light band tension.

Check the file band to see that it is in alignment and will pass freely over the channel in the file guide. Then shift the machine into low gear and start the drive motor. Observe the file band (figure 32) to be sure that it is tracking properly.

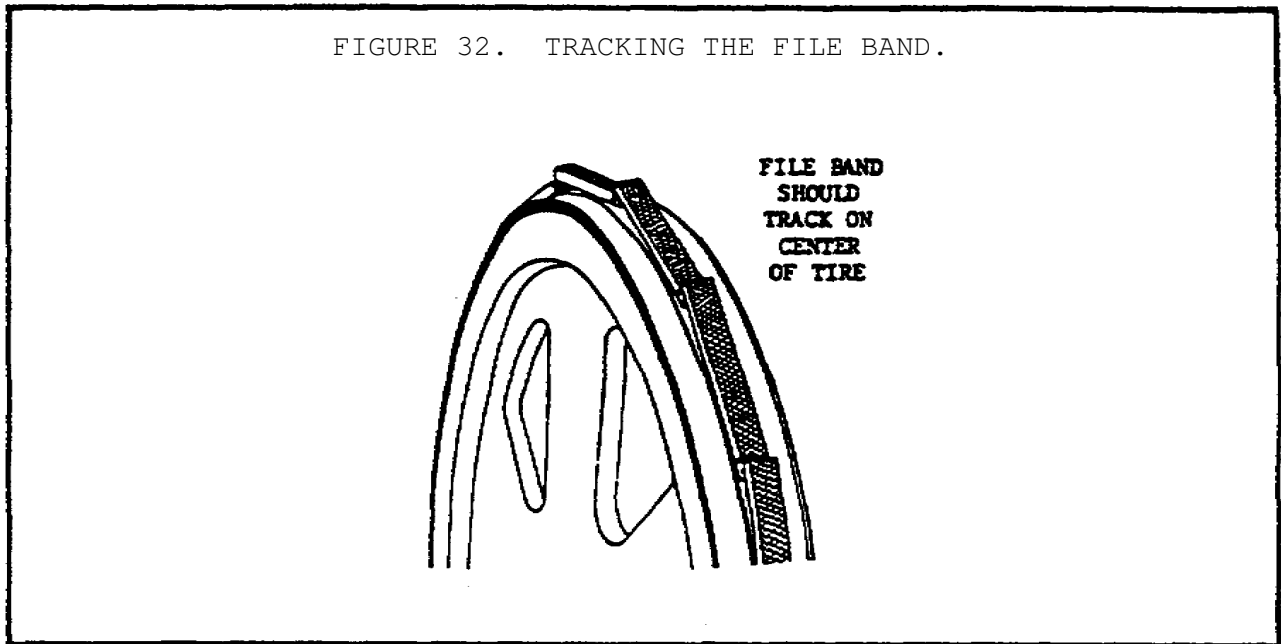

CAUTION

File segment must travel with the riveted section down; if not, injury to operator and damage to file band and bandsaw will occur.

(8) *The Filing Operation.* During the filing operation, the correct combination of speed and pressure will produce curled chips. The best filing speeds are between 80 and 150 fpm. For internal filing, unlock the band and run it through the opening in the workpiece; then reassemble the band. Keep the files clean. Do not file when the

BANDSAW OPERATIONS - OD1646 - LESSON 1/TASK 1

teeth are loaded. Loaded files cause bumpy filing and scratch the workpiece. Excessive filing pressures when the file segments are clogged with chips will cause the file teeth to strip out. Use a file card or brush to clean the band before returning any file band to the storage cabinet.

(9) *Removing the File Band.* To remove the file band, release the tension by lowering the upper wheel, and slip the band off the wheels. To separate the band after it has been removed from the wheels, perform these steps:

(a) Hold the band at the joint with both hands, with the yellow segment in the left hand.

(b) Bend the joint to not more than a 12 inch radius, exposing the joint slot.

(c) Using the forefinger of the left hand, depress the front end of the yellow file band.

With the thumb and forefinger of the right hand, disengage the dowel.

(d) Slide the lock rivet to the open end of the slot and lift off.

(e) For storage after removal, the file band should not be coiled into more than three loops.

f. *General Polishing Operations.* Polishing bands and a polishing attachment are provided with the bandsaw machine so that light polishing operations can be performed. The polishing bands are intended primarily for removing saw marks on the cut edges of workpieces.

(1) *Polishing Attachment.* A polishing attachment (figure 33 on the following page) is provided with most bandsaw machines to allow the machine to be used for polishing. The attachment, similar to the band file attachment, provides support for the polishing band, together with the polishing band plate which is supported between the post and frame of the bandsaw machine. The polishing band plate acts as a solid backing for the polishing band to prevent stretching and distorting the polishing band when the workpiece is held against it. A polishing band filler plate is used to fill the table slot so the workpiece can be supported close to the polishing band.

BANDSAW OPERATIONS - OD1646 - LESSON 1/TASK 1

(2) *Polishing Bands.* When the polishing attachment has been installed on the bandsaw machine and the bandsaw blade has been replaced by the polishing band, polishing operations can be performed on the bandsaw machine. The polishing band is usually one inch wide, and has a heavy

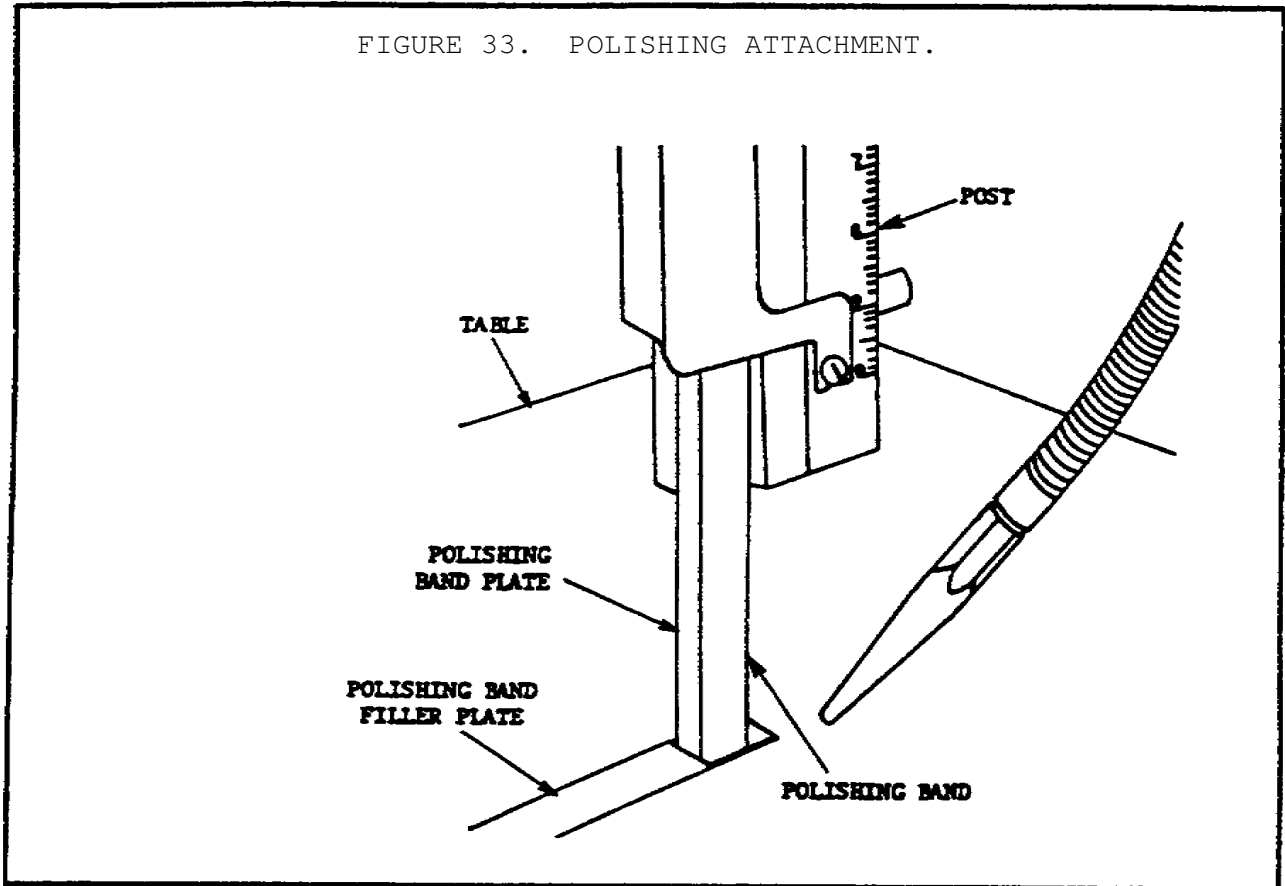

fabric backing. Polishing bands are manufactured to withstand high finishing and polishing temperatures. Abrasive bands are mounted over the wheels in the same manner as saw bands; however, a rigid backup support which has a graphite impregnated facing is used. This polishing guide support (figure 34 on the following page) is mounted to the post in place of the saw guides.

(a) *Types of Polishing Bands.* Polishing bands for bandsaw machines are usually supplied in three grain sizes of aluminum oxide or silicone carbide abrasive. Number 50 grain (coarse-medium) is used for light grinding operations, soft materials, and heavy stock removal with the bandsaw machine. Number 80 grain (medium-fine) is used for coarse polishing operations and general surface finishing.

Number 120 (or number 150) grain (fine) should be used for fine polishing operations. The bands are preformed in continuous bands in appropriate sizes to fit the bandsaw machine.

FIGURE 34. BAND POLISHING GUIDE.

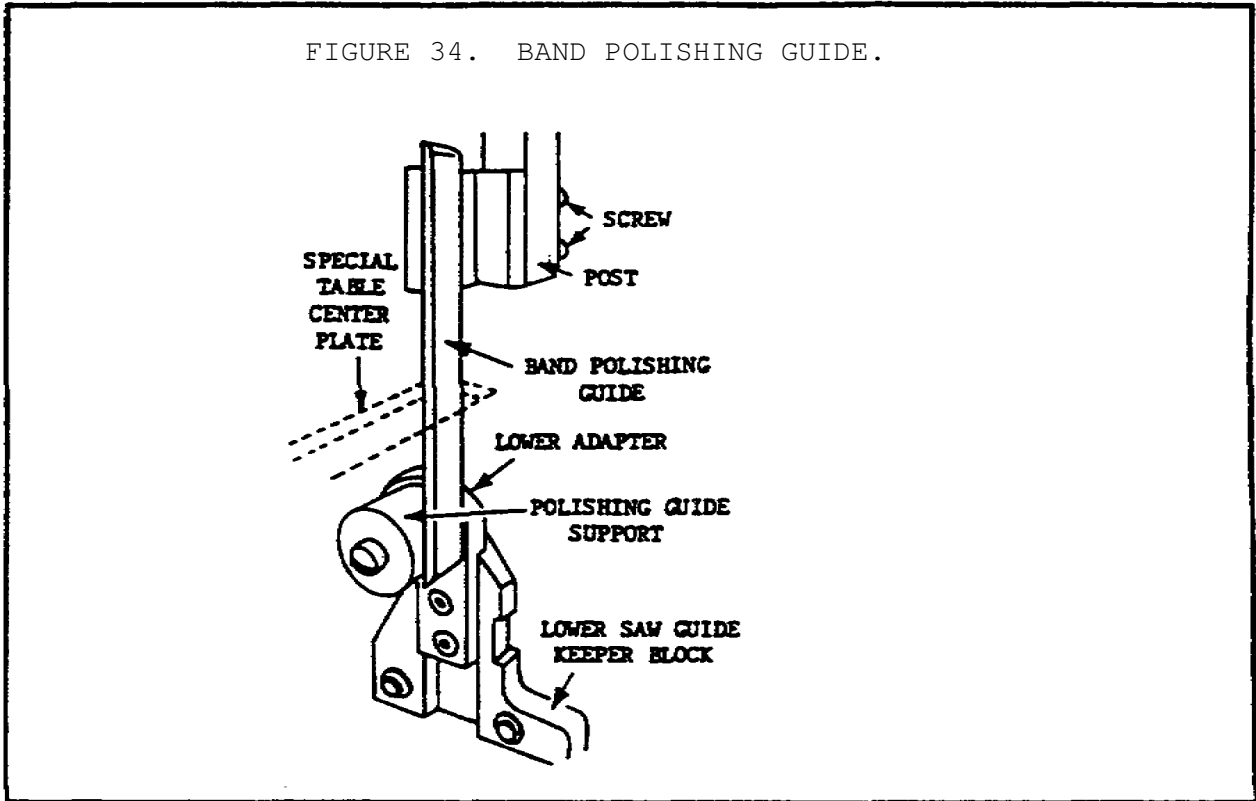

(b) *Selection of Polishing Bands.* Polishing bands should be selected according to the particular job to be performed. For general removal of tool marks and for smoothing edges, the number 50 grain polishing band should be used. This band will remove small amounts of metal by grinding, and is not, in the true sense of the word, a polishing band. When finer-grain polishing bands are used on the bandsaw machine, soft metals like aluminum or cast iron should not be polished, or the band will quickly fill with metal particles, reducing the cutting action of the polishing band.

(3) *Polishing Speeds.* Polishing bands should be moved at speeds between 75 and 260 feet per minute (fpm), the faster speeds being used for softer materials and the slower speeds being used for harder materials. The band speed for polishing is determined by the application. For grinding, a 50 grain polishing band should be used at speeds between 50 and 300 fpm. For general/coarse

BANDSAW OPERATIONS - OD1646 - LESSON 1/TASK 1

polishing, a 80 grain polishing band should be used at speeds between 850 and 1000 fpm. For fine polishing, a 120 (or 150) grain polishing band can be used at speeds between 850 and 1500 fpm.

(4) *Polishing Feeds.* Feeds should be light for polishing operations. Use a slow, sideways motion so that the polishing band will leave no marks on the workpiece. If the band does not remove the tool marks quickly, a coarser polishing band should be used.

NOTE

The procedures used for polishing using bandsaw machine model 2612-1M are presented here as an example of band polishing procedures. Band polishing procedures are similar for all bandsaw machine models.

(5) *Setting Up for Band Polishing.* Set up for band polishing with the model 2612-1M bandsaw machine using these steps:

(a) Remove the table center disk.

(b) Mount the polishing band guide backup support to the lower adapter as for filing.

(c) Lower the post to four inches from the table. Then mount the band polishing guide on the post and secure it with the two thumb screws.

(d) Occasionally, graphite powder should be rubbed into the guide fabric to lubricate and to increase the life of the polishing bands.

(e) Mount polishing band to travel in direction of arrow printed on the back side of polishing band. The correct polishing band tension is the same as that used for a 1/16 inch wide carbon saw blade.

(f) Install the special center adapter plate in the table.

(g) Do not use coolant with the polishing band.

5. Conclusion

The metal cutting vertical bandsaw machine has many uses. It can be used for straight or contoured sawing. It can make internal or external cuts. It can also be used for filing and polishing. Understanding how the bandsaw machine is used will help in performing the repair, adjustment, and troubleshooting procedures that will be described in lesson two.

BANDSAW OPERATIONS - OD1646 - LESSON 1/PE 1

PRACTICAL EXERCISE 1

1. Instructions

Read the scenario and respond to the requirements that follow the scenario.

2. Scenario

You have been assigned to a military advisory group (MAG) and will be traveling to Riyadh, Saudi Arabia. The purpose of the MAG assignment is to familiarize a group of their representatives with the use and maintenance of certain items of power equipment. It will be your job to make sure that the Saudi representative has enough knowledge of the bandsaw machines available to his people so that the machines may be safely used and properly maintained.

3. First Requirement

In an effort to introduce them to the capabilities of models of bandsaw machines that may be available to them, you are prepared to discuss, among others, the following attachments:

Choose from the list the accessory that is best described by each of the following statements:

Angular blade guide

Rip Fence

Disk cutting

Miter guide

Screw feed

a. The _____ is a device used for precision contour sawing of heavy work. It is a hand-operated method of feeding the workpiece into the blade or file.

b. The _____ attachment is a device used to support and guide workpieces to the bandsaw blade so that the workpiece may be cut at a specific angle.

BANDSAW OPERATIONS - OD1646 - LESSON 1/PE 1

c. The _____ attachment twists the bandsaw blade so that large or long workpieces that would not normally clear the bandsaw machine column can be cut.

d. The _____ attachment permits the cutting of true circles, either internally or externally.

e. The _____ helps in making even, straight cuts.

4. Second Requirement

Define or describe the following:

a. Kerf

b. Raker setting

c. Pitch of teeth

d. Annealing

e. Bastard-cut files

5. Third Requirement

During the annealing process, the welder and blade have been properly set up. Describe the annealing process on the model 2612-1M bandsaw machine for (a) carbon blades and for (b) Dart blades.

BANDSAW OPERATIONS - OD1646 - LESSON 1/PE 1

LESSON 1. PRACTICAL EXERCISE - ANSWERS

1. First Requirement
 - a. Screw feed device
 - b. miter guide
 - c. angular blade guide
 - d. disk cutting attachment
 - e. rip fence
2. Second Requirement
 - a. A kerf is a cut made by a bandsaw blade.
 - b. The raker setting is the setting of the teeth for most bandsaw machines. Raker tooth blades have one tooth bent to the right, the next tooth bent to the left, and the third tooth set straight.
 - c. The pitch of bandsaw blade teeth is the number of teeth per linear inch of the blade.
 - d. Annealing is the process or reheating metal and allowing it to cool slowly, thereby returning it to an approximation of its original temper.
 - e. bastard-cut files are double-cut files of medium pitch, usually used for filing steel and other hard metals.
3. Third Requirement
 - (a) *Carbon Blades.* If a carbon blade is being annealed on the model 2612-1M bandsaw machine welder, press and jog the anneal switch pushbutton until the weld is a dull cherry to cherry red in color. Then allow the blade to cool slowly by decreasing the jogging frequency.
 - (b) *Dart Blades.* To anneal a Dart blade, heat the blade slowly until the weld becomes a deep blue color. Continue to heat by jogging the anneal switch pushbutton until the width of the blue color is one-half the length of the band exposed between the jaws. Do not overheat or the temper of the band adjacent to the weld will be damaged. Cool quickly by releasing the button.

BANDSAW OPERATIONS - OD1646 - LESSON 2/TASK 1

LESSON 2

BANDSAW MAINTENANCE AND TROUBLESHOOTING

TASK 1. Describe the methods used to repair and adjust the bandsaw.

CONDITIONS

Within a self-study environment and given the subcourse text, without assistance.

STANDARDS

Within one hour

REFERENCES

No supplementary references are needed for this task.

1. Introduction

A knowledge of the procedures for properly operating a bandsaw machine will be helpful in learning how to maintain the machine, and will be particularly useful in learning to isolate the causes of malfunctions in bandsaw machines. In this task, the procedures required for performing maintenance on three models of bandsaw machines will be discussed. These models are: model 1612-0, model 2612-1M, and model 2614-1.

In the second task of this lesson, the troubleshooting procedures for these three bandsaw models will be described.

2. Maintenance Procedures for the Model 1612-0 Bandsaw Machine

Maintenance procedures for the model 1612-0 bandsaw machine include replacing the wheel tires, checking and adjusting the wheel brushes, adjusting and replacing drive belts, lubricating the head assembly, cleaning and lubricating the variable speed pulley, and replacing the saw guide backup

BANDSAW OPERATIONS - OD1646 - LESSON 2/TASK 1

bearing caps. Maintenance of the electric motor is accomplished by following the manufacturer's instructions located on the tag attached to the motor. Lubrication requirements can be found, when needed, in TM 9-3419-227-10, page 27.

a. *Wheel Tires.* When the tires are completely worn out, they should be replaced. Replace them by loosening the tire with a screwdriver. Stretch the tire until it can be removed. Scrape the wheel clean, and apply new cement before installing a new tire.

b. *Wheel Brushes.* The wheel brush should be checked occasionally. If it is worn so that it is no longer contacting the wheel face, loosen the adjusting screws and move the brush up to the wheel. Replace the brush as required.

c. *Drive Belts.* The belts driving the speed indicator and the input sheave will stretch slightly after initial use. The stretch of the belts is automatically taken up by the counterbalancing weight of the drive motor (figure 35 on the following page) on its mounting hinge.

(1) *Replacing the Belts.* The belts can be easily replaced by lifting up the drive motor and blocking it in place. After the drive motor is lifted and blocked, the belts can be slipped off their pulleys and new belts can be installed.

(2) *Adjusting the Motor Bracket.* The motor bracket (figure 35) is adjusted to control "hopping" or climbing of the drive motor in its belt. Adjust the bracket to just clear the motor plate when at its highest position during operation.

d. *Head Assembly.* The head assembly on the model 1612-0 bandsaw machine is shown in figure 36 on page 56. Access to the head assembly can be easily gained by lifting the upper wheel up and out of the bracket on the slide assembly (refer to figures 35 and 36). Oil should occasionally be wiped on the post, and the post should be run up and down through the slide block several times. The upper wheel slide and band tension screw should be oiled monthly. The wheel bearings are sealed and lubricated for life.

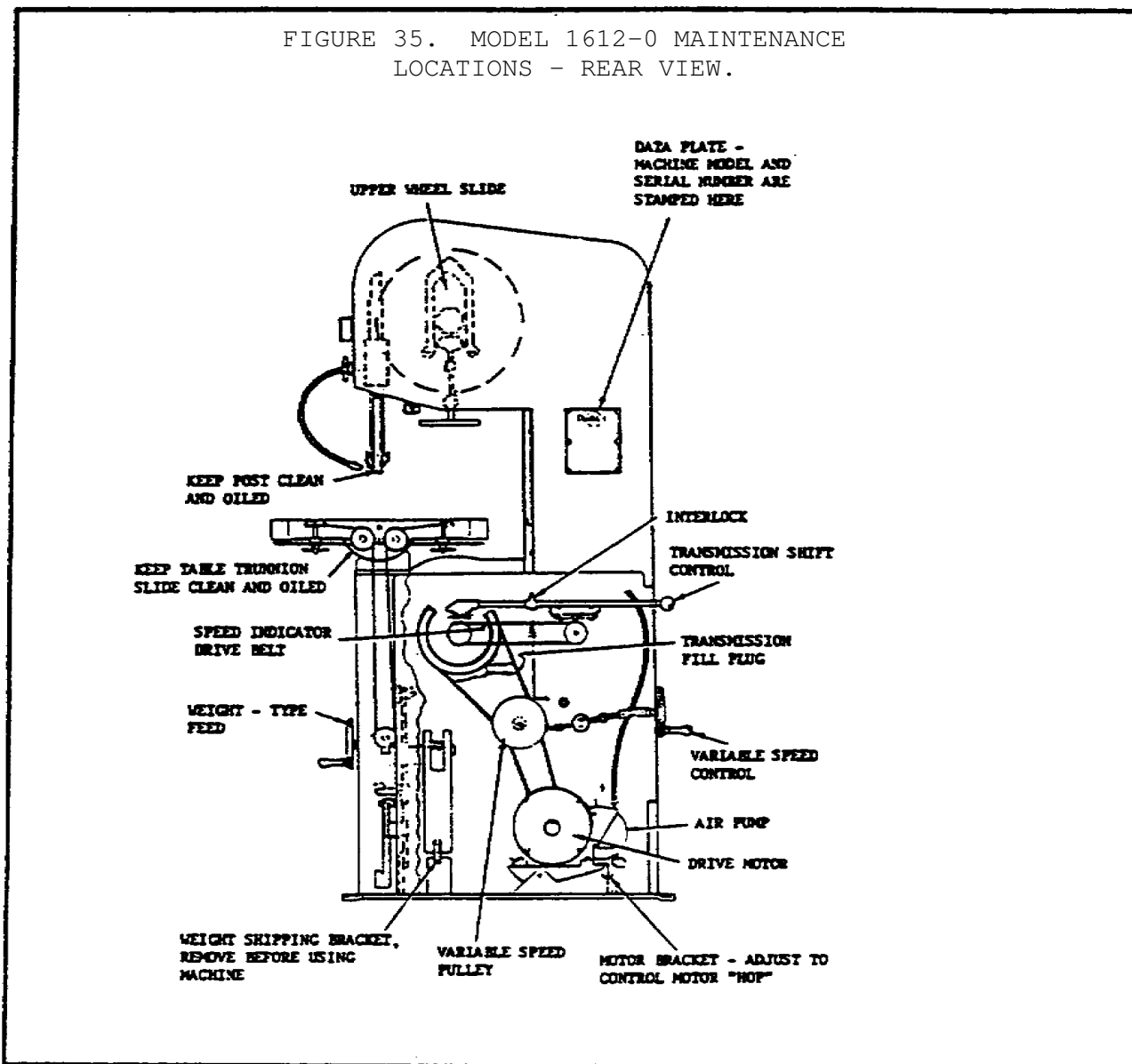

e. *Variable Speed Pulley.* Every six months, the variable speed pulley unit should be removed. It should be washed and cleaned with solvent. Then it should be reoiled and installed. The pulley shaft bearings are lubricated from an oil cup (figure 37 on the following page) in the shaft end. The center sheave, which floats sideways as well as rotates, is lubricated by a wick which is immersed in oil which travels through the hollow shaft from the oil cup. Check to be sure the center sheave of the pulley is free to shift sideways. The faces of the variable speed pulley should be checked for scoring which could damage the belts.

FIGURE 36. THE HEAD ASSEMBLY (MODEL 1612-0).

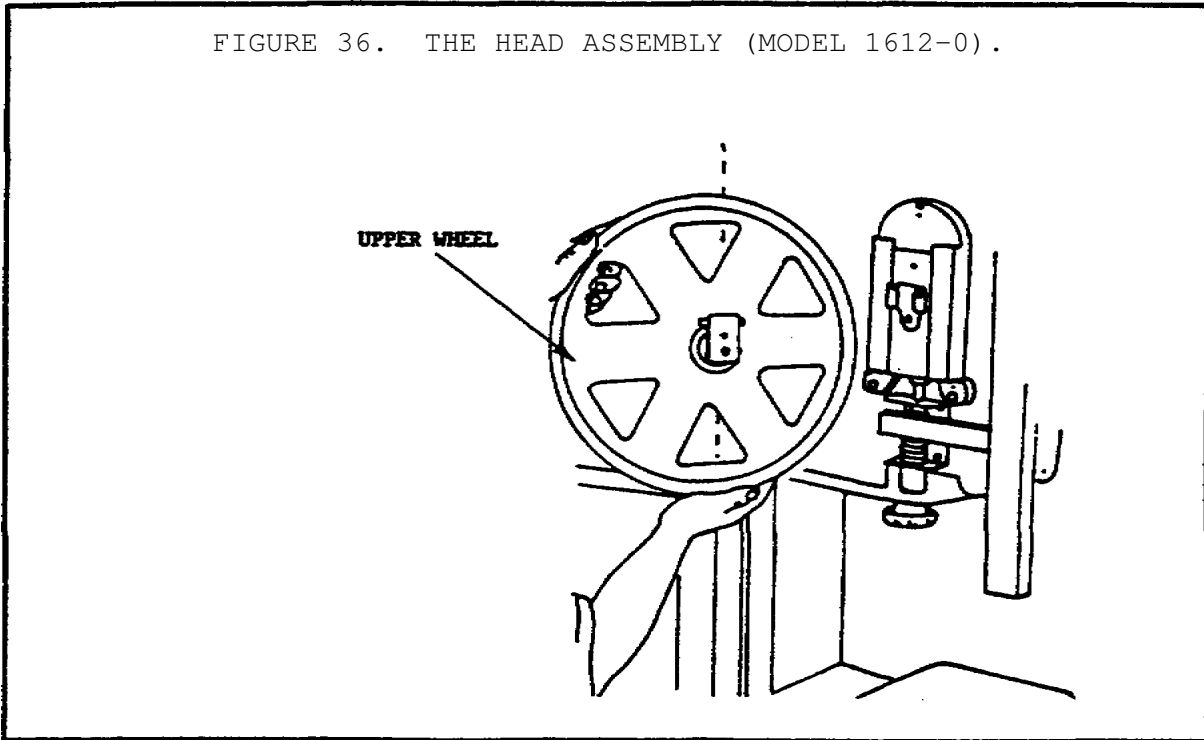
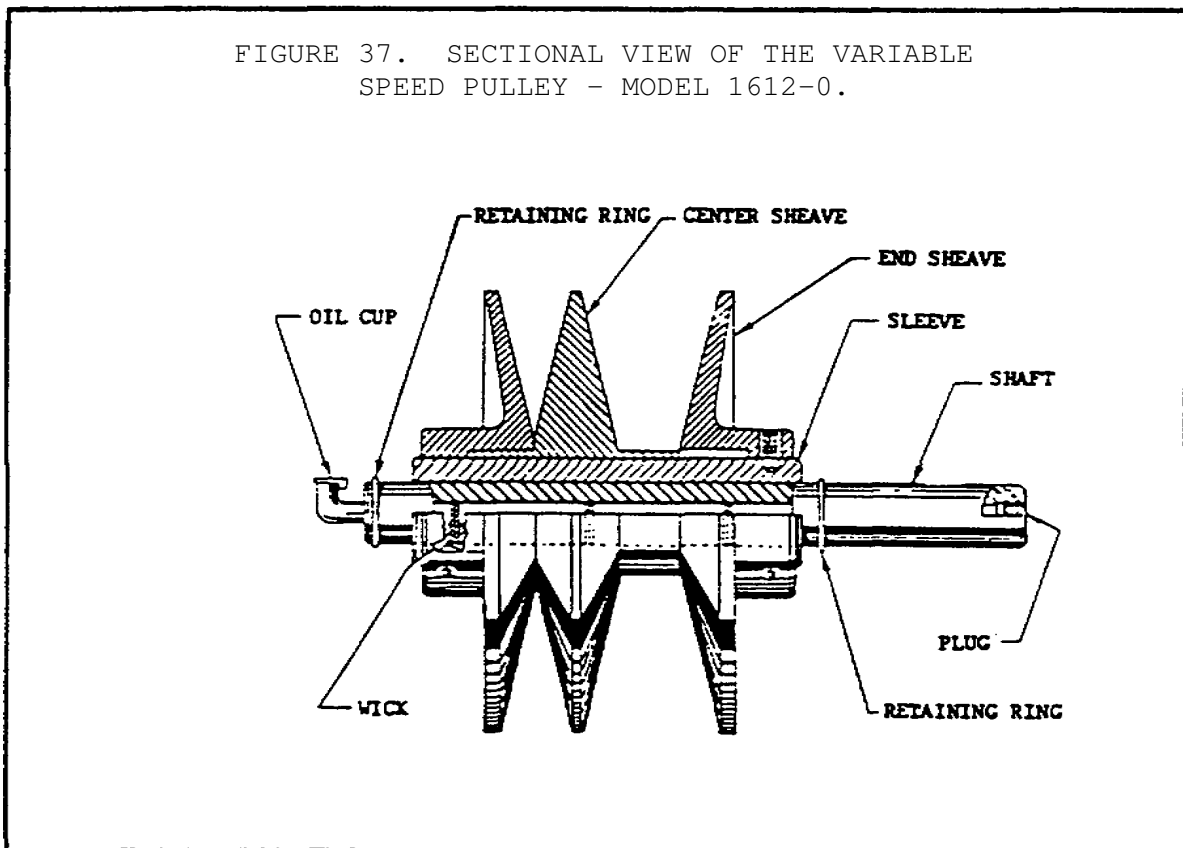

FIGURE 37. SECTIONAL VIEW OF THE VARIABLE SPEED PULLEY - MODEL 1612-0.



CAUTION

Do not over-lubricate, since oil will coat the belts and cause slippage.

f. *Saw Guides.* When the saw guide backup bearing caps become worn or grooved, they should be replaced. On the 1/16 to 1/2 inch guides, the bearings, caps, and shaft are replaced as a unit. When replacement is required, loosen the set screw holding the bearing assembly. Then replace the complete assembly. On the 5/8 to 3/4 inch guides, the bearing cap and shaft are replaced by removing the snap ring and pulling out the bearing cap and shaft. The bearings are installed with a light press fit and can be easily replaced. Both types of bearings are permanently lubricated and need no further lubrication.

g. *Air Pump.* The rotary air pump on the model 1612-0 bandsaw machine should not be oiled. The vanes are made of plastic, and oil tends to destroy them. Use powdered graphite very sparingly. This graphite is forced into the pump through the air inlet while the pump is in motion. Remove the air cleaner and wash it in gasoline or solvent monthly.

3. Maintenance Procedures for the Model 2612-1M Bandsaw Machine

Maintenance procedures for the model 2612-1M bandsaw machine include adjusting and replacing the wheel brushes, replacing the wheel tires, cleaning and lubricating the variable speed pulley, replacing the saw guides, adjusting and replacing the drive belts, adjusting the band tension indicator on the head assembly, and flushing the transmission. The electric motor is maintained following the manufacturer's instructions located on the tag attached to the motor.

a. *Wheel Brushes.* The wheel brushes should be checked occasionally. If a brush is worn so that it is no longer contacting the wheel face, the adjusting screws should be loosened and the brush moved up to the wheel. A worn brush should be replaced.

b. *Wheel Tires.* To replace a wheel tire (figure 38 on the following page), follow this procedure:

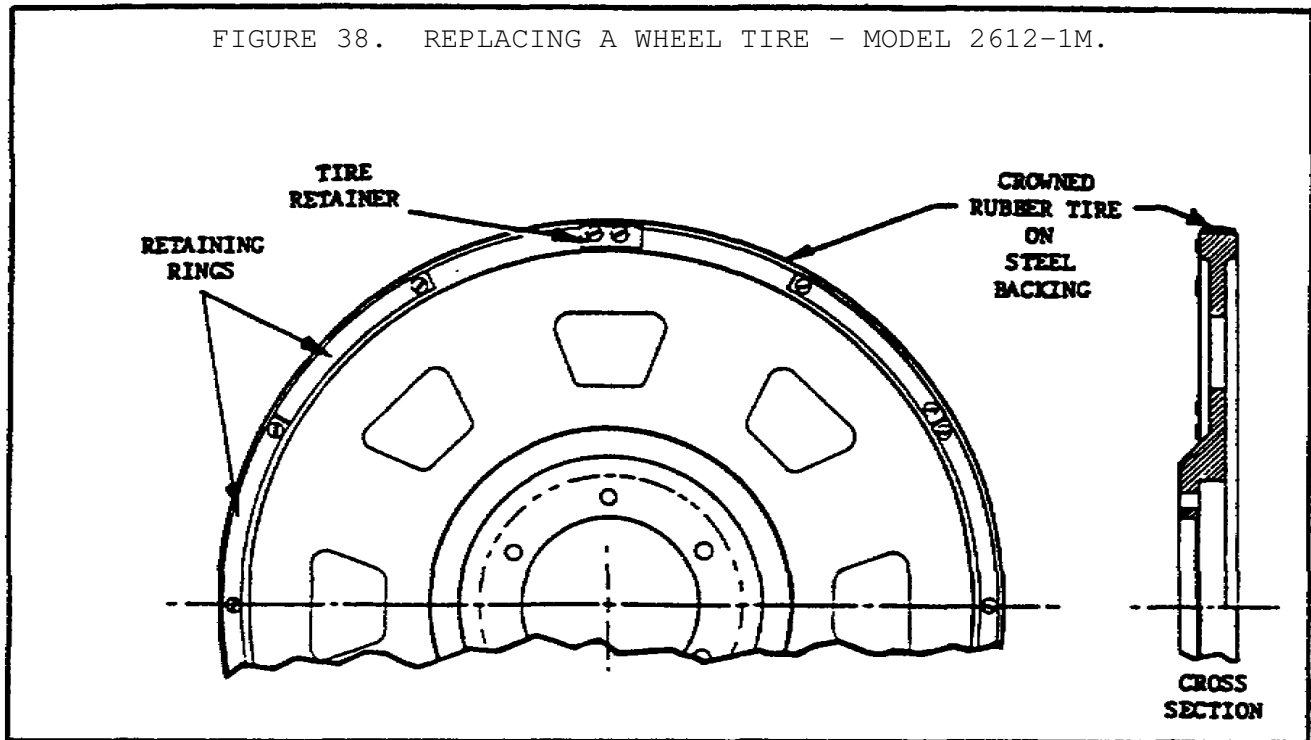

- (1) Remove the two retainers from the front of the band wheel.
- (2) Remove the tire retaining rings.
- (3) Drive the tire off the wheel. If necessary, saw off the steel backing.
- (4) Mount new tires so that the two notches in the steel backing are in alignment with the two tire retainers.
- (5) Put the new tire on with light taps of a soft-faced hammer, rotating the wheel about 30 degrees as each tap is made, until the tire is against the flange of the wheel.
- (6) Replace the retainers and the tire retaining rings.

c. *Variable Speed Pulley.* Every six months, the variable speed pulley unit (figure 39 on the following page) should be removed so that it can be washed and cleaned with a solvent. After it has been cleaned, it should be reoiled and installed. Check the pulley to see if the center sheave is free to shift sideways. The variable shaft bearings are lubricated from an oil cup in the shaft end. The center sheave, which floats

sideways as well as rotates, is lubricated by a wick which is immersed in oil. This oil travels through the hollow shaft from the oil cup. The variable speed pulley faces should be checked for scoring which could damage the belts.

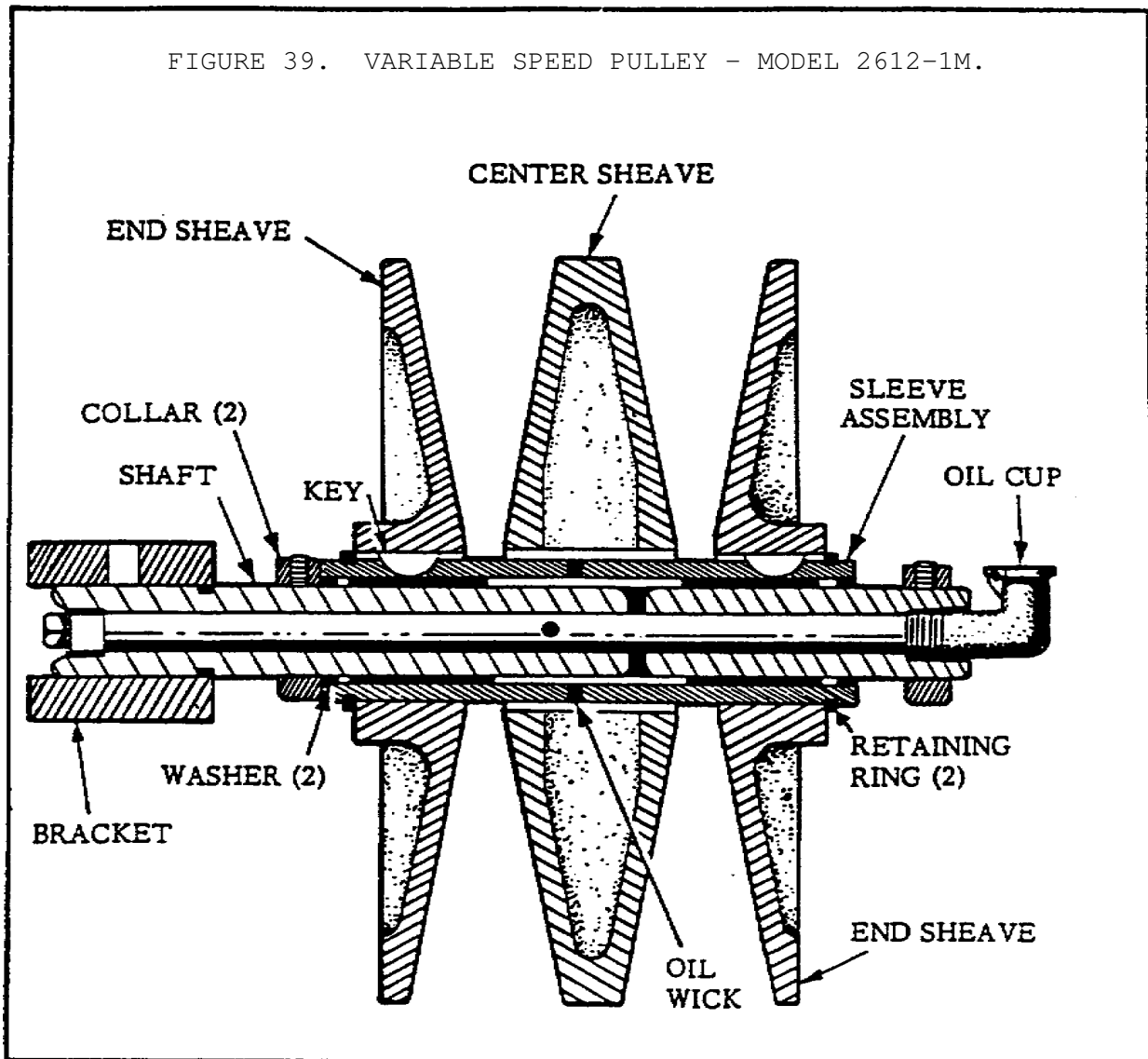

CAUTION

Do not over lubricate the pulley. Excess lubrication could coat the belts and cause slippage.

d. *Saw Guides.* The saw guide bearings are replaced by removing the snap ring and pulling out the bearing cap and shaft. The bearings are installed with a light press fit, and can be easily

BANDSAW OPERATIONS - OD1646 - LESSON 2/TASK 1

replaced, when required. The bearings are sealed and packed for life with a special lubricant.

e. *Drive Belts.* The belts driving the variable pulley and input sheave will stretch slightly after initial use. The stretch of the belts is automatically taken up by the counterbalancing weight of the drive motor on its mounting plate (figure 40). The motor is mounted on a pivoted plate. The large spring to the left of the pivot is adjusted to counterbalance the weight of the motor on the drive belts.

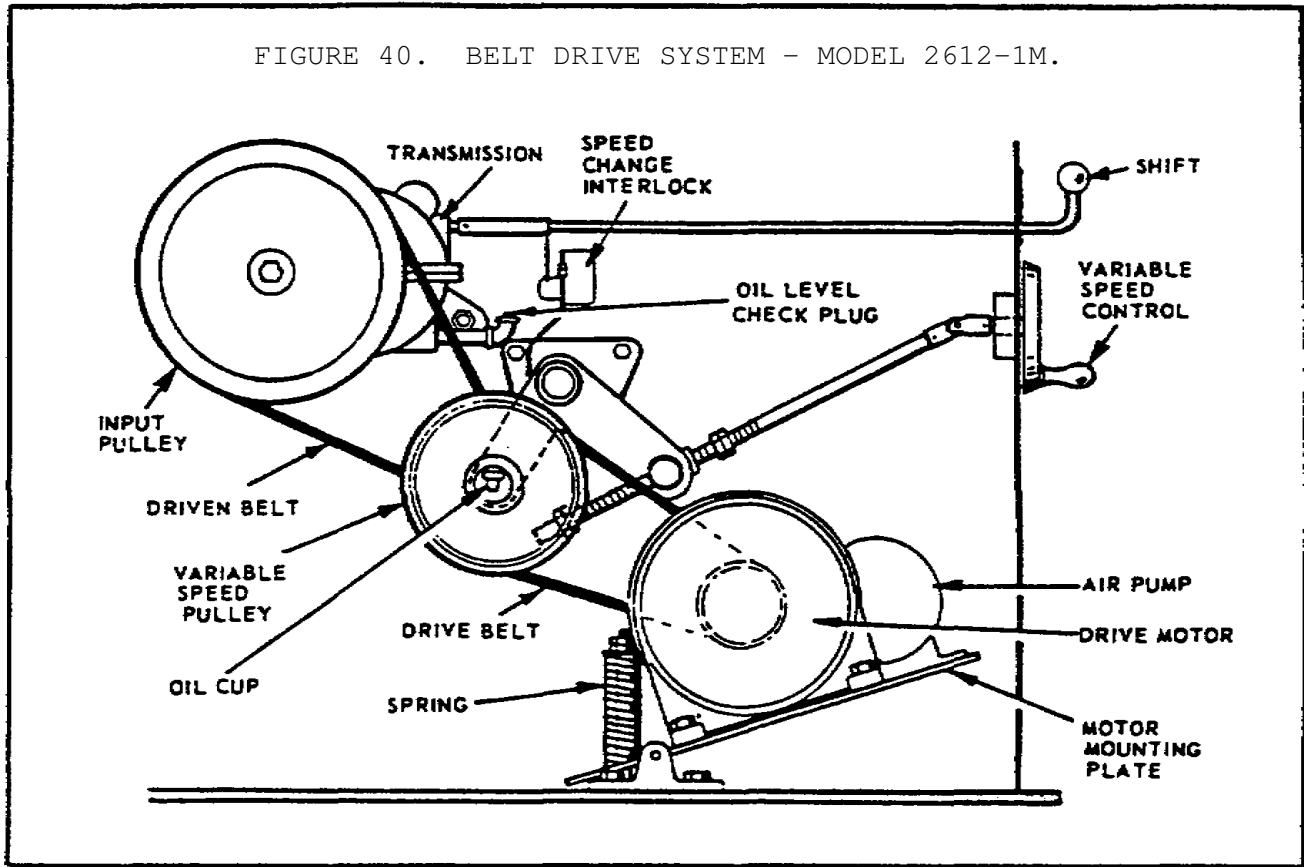

(1) *Adjusting the Belts.* To adjust the belts, adjust the nuts on the counterbalance spring so that there is enough tension on the drive belts to prevent slippage. If the motor is insufficiently counterbalanced, unnecessary wear on the variable pulley sheaves, bearings, and shaft will result. Too much counterbalance will cause the motor to "climb the belt" or "hop" excessively.

(2) *Changing the Belts.* To change the belts on the model 2612-1M bandsaw machine, perform these steps:

BANDSAW OPERATIONS - OD1646 - LESSON 2/TASK 1

(a) Loosen the air pump mounting bolts enough to move the pump and remove the belt.

(b) Tilt the pivoted motor plate, and place a block under it.

(c) After the motor plate is blocked, the two drive belts can be removed and replaced with new belts.

f. *Head Assembly.* The wheel bearings are sealed and lubricated for life. If it is necessary to adjust the band tension indicator, first loosen the set screw clamping the wire leading to the indicator. Then take all the slack out of the band with the band tension control. Adjust the indicator pointer to zero and lock the linkage arm to the wire. A more accurate calibration can be obtained by using a band tension measuring instrument.

g. *Transmission.* The transmission should be drained, flushed, and refilled after the first month of use, and then at least every six months. It should be filled until the oil level is at the level of the filler plug in the elbow. Use SAE number 20 oil. Check for seal leaks around the shafts. Any rough operation, vibration, loud or unusual noises should be investigated immediately. It is recommended that the transmission be returned to the factory for repairs. Installing a new transmission correctly is extremely important because of the careful alignment involved. If the shifter plate has been removed for any reason, do not attempt to operate the shift lever.

4. Maintenance Procedures for the Model 2614-1 Bandsaw Machine

Maintenance procedures for the model 2614-1 bandsaw machine include lubrication of the head assembly, adjustment of the band tension indicator, replacement of the wheel tires, adjustment of the wheel brushes, and flushing the transmission. Maintenance of the electric motor is limited to the manufacturer's instructions located on the tag attached to the motor.

a. *Head Assembly.* The wheel bearings are sealed and lubricated for life. The upper wheel slide and the band tension screw are lubricated by grease fittings. Occasionally, oil should be wiped on the

BANDSAW OPERATIONS - OD1646 - LESSON 2/TASK 1

post, and the post should be run up and down through the slide block several times. If it is necessary to adjust the band tension indicator, first loosen the setscrew clamping the wire leading to the indicator. Then take all the slack out of the band with the band tension control. Adjust the indicator pointer to zero and lock the linkage arm to the wire. A more accurate calibration can be obtained by using a band tension measuring instrument.

b. *Wheel Tires.* When the wheel tires are completely worn out, they should be replaced. This is accomplished by loosening the tire with a screw driver and stretching it until it can be taken off. The wheel should then be scraped clean. New cement must be applied before installing a new tire.

c. *Wheel Brushes.* Check the wheel brush (figure 41) occasionally. If it is worn so that it is no longer contacting the wheel face, loosen the adjusting screws and move the brush up to the wheel. Replace the wheel brush as needed.

FIGURE 41. ADJUSTING WHEEL BRUSHES - MODEL 2614-1.

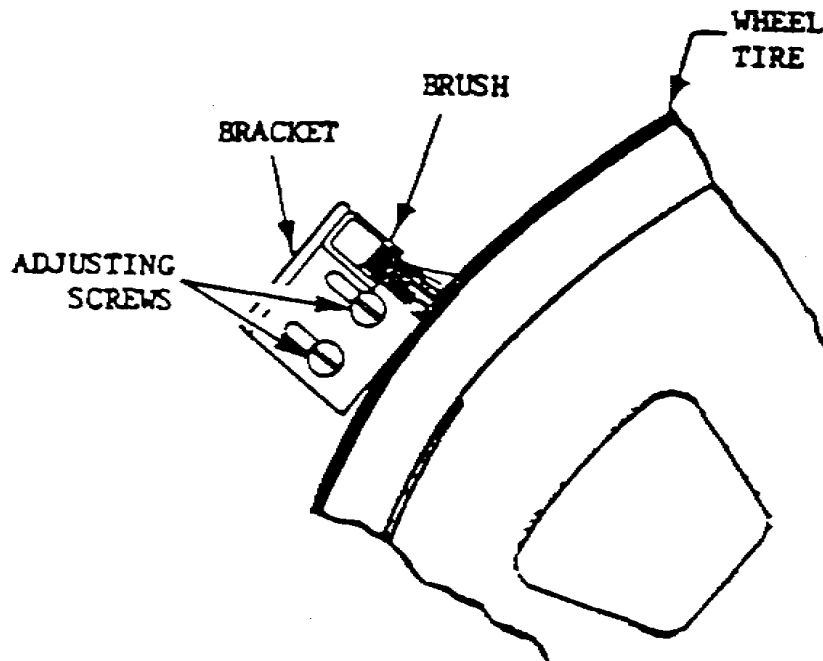

d. *Transmission.* Check the oil level of the transmission (figure 42) as required. After the first month of operation and at least every six months after that, the transmission should be drained, flushed, and refilled. Fill the transmission to the top of the fill pipe, but do not overfill. Use high quality, rust and oxidation inhibited, medium hydraulic and general purpose industrial oil, ASTM grade number 315. Check for seal leaks around the shafts. Any rough operation, vibration, loud or unusual noises should be investigated immediately. Since installing a new

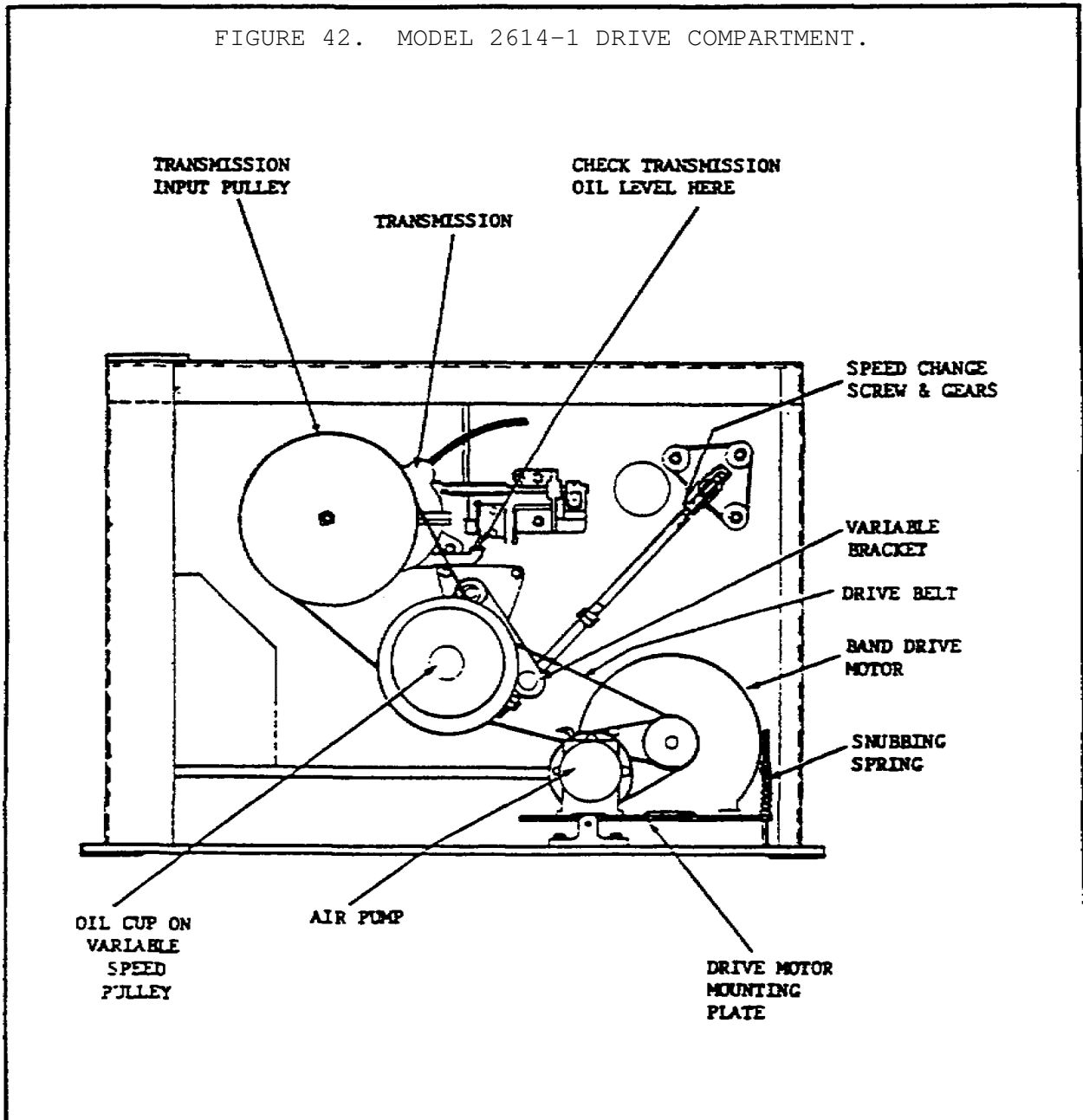

BANDSAW OPERATIONS - OD1646 - LESSON 2/TASK 1

transmission correctly is extremely important because of the careful alignment involved, it is recommended that the transmission be returned to the factory when repairs are required. If the shifter plate has been removed for any reason, do not attempt to operate the shift lever.

5. Conclusion

It is obvious that many of the maintenance procedures for the three bandsaw machines being described here are similar. A firm grasp of these maintenance procedures will be helpful in isolating faults when troubleshooting, as described in the next task.

BANDSAW OPERATIONS - OD1646 - LESSON 2/TASK 2

LESSON 2

BANDSAW MAINTENANCE AND TROUBLESHOOTING

TASK 2. Describe the procedures for troubleshooting the bandsaw.

CONDITIONS

Within a self-study environment and given the subcourse text, without assistance.

STANDARDS

Within two hours

REFERENCES

No supplementary references are needed for this task.

1. Introduction

Lesson one provided a description of the uses of a bandsaw machine and the proper methods for operating a vertical bandsaw machine. In the first task of lesson two, maintenance procedures for three different bandsaw machines were discussed. A thorough working knowledge of operational and maintenance procedures is required before troubleshooting procedures can be accomplished. This task will discuss the procedures used for isolating malfunctions (troubleshooting) for these three models of bandsaw machines.

2. General Troubleshooting

When a problem occurs in equipment, from the failure of either a mechanical or electrical component, it is necessary to understand how to isolate the cause of the problem so that it can be fixed. Troubleshooting is the logical process used to isolate the cause of a malfunction by identifying the symptoms, isolating the fault so that corrective action can be taken.

BANDSAW OPERATIONS - OD1646 - LESSON 2/TASK 2

a. *Identifying the Symptom.* The identification of the symptom of a malfunction in one of the three models of bandsaw machines is merely a descriptive statement of what is going wrong during an attempt to operate the machine. Examples might be: TRANSMISSION WILL NOT STAY IN GEAR or SURFACE FINISH ON WORK TOO ROUGH.

b. *Isolating the Fault.* Once the symptom has been accurately described, it is necessary to isolate the cause of the problem. This is done by performing steps in a logical sequence as described in the appropriate technical manual (TM). These fault isolation steps are organized so that the most frequent or obvious possibilities are checked first and the rarer causes of the malfunction symptom are performed last, if the cause of the malfunction has still not been found.

c. *Correcting the Fault.* The fault isolation steps listed in the appropriate TM for any given symptom should be performed only up to the point where a fault is found. The component causing the problem should then be checked, adjusted, or replaced, and the bandsaw machine test operated to ensure that the problem has been fixed. If the problem still exists, fault isolation using the troubleshooting list should continue until test operation proves that the fault has been corrected. Usually, when troubleshooting the bandsaw machine models discussed in this subcourse, the fault remedy is self-evident. For example, if the fault isolation list requires that the transformer be checked, and the transformer is found to be bad, then the transformer should be replaced. Following replacement, test operation should be performed to confirm that the malfunction no longer exists.

NOTE

The emphasis of this task is to describe troubleshooting procedures, i.e., the isolation of the causes of specific malfunctions in bandsaw machines. Since the corrective procedures for most of the problems are self-evident, they will not be discussed in detail in this subcourse. When performing actual troubleshooting, always have the appropriate TM available, and follow the procedures described there.

3. Troubleshooting Fault Symptoms in the Model 1612-0 Bandsaw Machine

The malfunction symptoms and their possible causes for problems in the model 1612-0 bandsaw machine are described below. As stated earlier, the remedies for these possible causes will not be discussed in detail here. Operational solutions to problems, such as selecting a blade of the proper pitch, can be found in TM 9-3419-227-10, pages 8 through 26. Lubrication and maintenance solutions for malfunctions can be found in TM 9-3419-227-10, on pages 27 through 31. This TM should always be available before actual repair or troubleshooting procedures are performed.

a. *Troubleshooting the Malfunction: MACHINE WILL NOT START.* When the model 1612-0 bandsaw machine will not start, three checks should be made in an attempt to locate the cause of the problem.

(1) First, check the main fuses and the control circuit fuse. Replace any fuse that is defective. If a fuse is replaced, try to start the machine to see if the problem has been solved. If the machine still will not start, perform the next step.

(2) Check the reset on the band drive motor starter (if a starter is used). Starting and stopping the machine a number of times in quick succession, or an overload, will trip the starter heater. After locating and correcting the trouble, push in the reset button. If the heater relay has been set for automatic operation, it will not be necessary to push the reset button, but will only be necessary to wait for the relay to cool. Try starting the machine. If the machine will not start, perform the next step.

(3) Check the transformer, and replace it if necessary. Test operate to ensure that the problem has been fixed.

b. *Troubleshooting the Malfunction: SEVERE MACHINE VIBRATION.* There are three possible causes for severe machine vibration.

(1) Check to see if the band wheels are balanced. If the band wheels are not balanced, machine vibration could result. Balance the wheels if necessary.

BANDSAW OPERATIONS - OD1646 - LESSON 2/TASK 2

(2) If the band wheels are balanced, and vibration is still present, check to see if the variable pulley components are balanced. If they are not balanced, vibrations could result. Balance the components of the variable pulley, if needed. Then test operate to see if the trouble has been fixed.

(3) If severe machine vibration is still present, check to see whether the variable drive belts are unbalanced. Balance the drive belts, if required, then test operate to ensure that the malfunction no longer exists.

c. *Troubleshooting the Malfunction:* SEVERE SAW BAND VIBRATION DURING SAWING. When severe saw band vibration occurs during sawing operations, make these checks:

(1) Check the band speed. Saw band vibration can be caused by the selection of the incorrect band speed.

(2) If the band speed is correct, the pitch of the saw blade may be incorrect. Check the pitch of the saw blade, and select a blade of the proper pitch.

(3) If a blade with the proper pitch is in use, but severe saw band vibration is still present, the choice of coolant may be incorrect. Select the proper coolant to solve this problem.

(4) If the coolant being used is correct, it is possible that the feed pressure is incorrect. Vary the feed pressure to see if this is causing the trouble.

(5) Severe saw band vibration can occur if the work piece is not firmly clamped to the table. If this is the case, adjust the clamps to solve the problem.

(6) Worn or improperly adjusted saw guide inserts can cause saw band vibration. Adjust or replace the saw guide inserts, as required.

(7) A worn saw guide backup bearing could be causing the problem. Check the saw guide backup bearing and replace it, if needed.

BANDSAW OPERATIONS - OD1646 - LESSON 2/TASK 2

(8) When the heavy work slide or the heavy work clamp is used, special support must be used under the workpiece. If special support is not used, saw band vibration could result.

d. *Troubleshooting the Malfunction:* TRANSMISSION WILL NOT STAY IN GEAR. If the transmission will not stay in gear, the most probable cause is worn gears. The machine should be returned to the factory for transmission repairs.

e. *Troubleshooting the Malfunction:* TRANSMISSION WILL NOT SHIFT INTO GEAR. Three conditions could cause the transmission to fail to shift into gear.

(1) It is possible that the transmission will not shift into gear because there is a loose setscrew or broken rollpins in the shift linkage. Check the shift linkage for a loosened setscrew and for broken rollpins and repair, as needed.

(2) If the components of the shift linkage are not causing the problem, the shift mechanism in the transmission may be jammed. If this is the case, the machine should be returned to the factory for service.

(3) The sliding clutch jaws in the transmission may be jammed or damaged, causing the transmission to fail to shift into gear. When this is the case, the machine should be returned to the factory for service.

f. *Troubleshooting the Malfunction:* SAW BAND IS CUTTING INACCURATELY. When the saw band is cutting inaccurately, a number of checks should be made to find the cause of the trouble.

(1) First, check for worn blade teeth. Replace the blade if the teeth are worn. Then test operate to see if the problem has been solved.

(2) If the scale on the workpiece has not been removed, inaccurate cuts will result. Remove the scale from the workpiece, if needed.

(3) The workpiece may have become hardened by the grinding performed to remove the scale.

(4) The blade may be too wide for the radius being cut. Check the blade width, and select the proper blade, if necessary.

BANDSAW OPERATIONS - OD1646 - LESSON 2/TASK 2

(5) The saw band or the insert may be improperly aligned. Make the required alignments, and test operate to see if the problem has been fixed.

(6) It is possible that inaccurate cuts are the result of the post not being square to the table. Correct this problem by squaring the post to the table.

(7) Using the incorrect feed force can cause inaccurate cuts. Adjust the feed force, as needed to correct the problem.

(8) Inaccurate band speeds can also cause inaccurate cuts. Adjust the speed, as needed to solve the problem.

(9) If coolant is not applied evenly to both sides of the saw band, inaccurate cuts may result. Check for this condition and correct it, if necessary.

(10) If the saw guide on the upper post is not located close enough to the workpiece, inaccurate cuts may result. Adjust the position of the saw guide, if needed.

(11) Choosing the incorrect saw band could cause the problem of inaccurate cuts. Select the correct saw band, as required.

(12) Inaccurate cuts can also result from incorrect saw band tension. More tension should be used for a Dart blade than for a carbon blade. Check the band tension, and adjust it, as needed.

g. *Troubleshooting the Malfunction:* SURFACE FINISH ON THE WORK IS TOO ROUGH. When the surface finish on the workpiece is too rough, then any of the following conditions could be the cause. Check these conditions and make corrections or adjustments, as needed:

(1) The saw guide inserts may be worn. Readjust them, as needed.

(2) The saw band speed may be too low.

(3) The saw band pitch may be too coarse.

(4) The feed may be too heavy.

BANDSAW OPERATIONS - OD1646 - LESSON 2/TASK 2

(5) Vibration could cause this condition. See paragraphs 3b, beginning on page 67, and 3c, beginning on page 68, to solve vibration problems.

h. *Troubleshooting the Malfunction: SAW BAND TEETH STRIPPING.* Saw band teeth stripping is usually caused by chip welding. It may also be caused by the following:

- (1) The saw band pitch may be too coarse for a thin work section.
- (2) The workpiece may not be held firmly enough to stop vibration.
- (3) The feed pressure may be too high.
- (4) The band speed may be too low.

i. *Troubleshooting the Malfunction: PREMATURE SAW BAND BREAKAGE.* Premature saw band breakage is usually caused by teeth stripping. It may also be caused by the following conditions:

- (1) The saw band speed may be too low. Adjust the speed as needed to correct the problem.
- (2) The feeding force may be too high. Adjust the feed, as required.
- (3) The pitch of the saw band may be too coarse. Use a finer pitch band.

j. *Troubleshooting the Malfunction: PREMATURE DULLING OF SAW BAND TEETH.* Premature dulling of the saw band teeth may be caused by any of these conditions:

- (1) The saw band must be broken in on the first few cuts by using a reduced feed pressure and speed. If the saw band is not broken in, dulling of the saw band teeth can occur.
- (2) The band speed may be too high, causing abrasion. Reduce the speed, as needed.
- (3) The saw band pitch may be too coarse. Choose a band with a finer pitch.
- (4) Premature dulling of the saw band teeth can occur if the wrong type of coolant is used, or if no coolant is used.

BANDSAW OPERATIONS - OD1646 - LESSON 2/TASK 2

(5) The feed pressure may be too light. Increase the feed pressure as required to solve the problem.

(6) The coolant may not be covering the saw band. Make adjustments, as needed.

(7) The cutting rate may be too high.

(8) The material being cut may be faulty, having a heavy scale, inclusions, hard spots, etc.

(9) The material analysis may be incorrect.

(10) Saw band vibration can cause premature dulling of the blade.

(11) If a chipped tooth is lodged in the cut, the saw blade will dull prematurely.

(12) Chip welding can also cause premature dulling of the blade.

(13) If the inserts are too large for the blade width, the inserts may hit the set teeth, causing the blade to dull prematurely.

k. *Troubleshooting the Malfunction:* MOTOR RUNS BUT THE BAND DOES NOT MOVE. Several conditions could cause the band to remain stationary even when the motor is running.

(1) The drive belts could be broken, or they may be off the pulleys. Replace or adjust the belts, as needed.

(2) Over-oiling of the variable pulley may have coated the pulley (and subsequently the belts) with oil, causing the belts to slip.

(3) The drive belt tension may be too low. Adjust the tension on the drive belt, as needed.

(4) Using the wrong size of drive belt can also cause this problem.

(5) If the band tension is incorrect, the motor could run while the band remained stationary.

l. *Troubleshooting the Malfunction:* BAND SLIPS OFF THE WHEELS. Three conditions could cause the band to slip off the wheels:

BANDSAW OPERATIONS - OD1646 - LESSON 2/TASK 2

(1) The upper wheel may not be aligned correctly, so that the band does not track on the center of the wheel tire. Adjust the track of the band, as required.

(2) Too much coolant or the wrong type of coolant can cause the band to slip off the wheel tires.

(3) The initial machine alignment may be wrong. When this is the case, refer to TM 9-3419-227-10, page 3 for the procedure needed to solve the problem.

m. *Troubleshooting the Malfunction: EXCESSIVE INSERT AND BLADE WEAR.* When there is excessive insert and blade wear, make these checks:

(1) Check to see if the inserts are adjusted too tight on the blade. Make adjustments as needed.

(2) Check to ensure that the band is being lubricated properly. High band speed causes friction. Coolant should be used to lubricate the band.

(3) Check to see if the rollers on the roller guides are adjusted too tight on the blade. Loosen the roller guides, if needed.

(4) The chip brush may be worn, or may not be adjusted properly, allowing the chips to stay on the wheel. Check for this condition, and make the necessary repairs.

n. *Troubleshooting the Malfunction: FILE BAND BREAKS.* When the file band breaks, two conditions could be the cause:

(1) The feed force may be too high. Adjust the feed force to solve the problem.

(2) The wrong type of file band may be in use. Make sure that a file band of the proper shape, width, and number of teeth is being used for the material in the workpiece.

o. *Troubleshooting When There is a POOR FINISH FROM BAND FILING.* A poor finish from band filing could be the result of any of the following conditions:

BANDSAW OPERATIONS - OD1646 - LESSON 2/TASK 2

(1) The feed force could be too high. Reduce the feed force, as needed.

(2) The file band may not be assembled correctly.

(3) The band tension may be too high. Set the band tension at the setting used for a 1/8 inch wide carbon band.

p. *Troubleshooting the Malfunction: FILE BAND TEETH BECOME LOADED.* If the band teeth become loaded, clean the teeth immediately and then check for these conditions:

(1) The feed force may be too high. Adjust the feed, as needed.

(2) It may be that no coolant is being used. Use coolant to improve the finish.

(3) The wrong shape of file may be in use, or the file may have the wrong number of teeth for the material of the workpiece.

q. *Troubleshooting When There is NO COOLANT FLOW.* If there is no coolant flow, check for the presence of one of these conditions and remedy the situation, as required:

(1) Check to see if the coolant applicator nozzle is jammed.

(2) Check to see if the coolant hose is clogged or kinked.

(3) Check to see if the coolant reservoir is empty.

4. Troubleshooting Fault Symptoms in the Model 2612-1M Bandsaw Machine

The malfunction symptoms, together with their possible causes, for the model 2612-1M bandsaw machine are similar to those described for the model 1612-0 machine. As stated earlier, the remedies for these possible malfunctions will not be discussed in detail here. Operational solutions to problems, such as adjusting the speed controls, can be found in TM 9-3419-228-10, pages 4 through 20. Lubrication instructions and maintenance solutions for malfunctions, such as adjusting the

BANDSAW OPERATIONS - OD1646 - LESSON 2/TASK 2

drive belts, can be found in TM 9-3419-228-10, on pages 21 through 25. This TM should always be referred to when actual repair or troubleshooting procedures are performed.

a. *Troubleshooting the Malfunction: MACHINE WILL NOT START.* When the model 2612-1M bandsaw machine will not start, three conditions could be causing the problem. To locate the source of the trouble, make these checks.

(1) First, check the main fuses and the control circuit fuse. Replace any fuse that is defective. If a fuse is replaced, try to start the machine to see if the problem is still present.

(2) If all the fuses are good but the machine will still not start, check the reset on the band drive motor starter (if a starter is used). Starting and stopping the machine a number of times in quick succession, or an overload, will trip the starter heater. After locating and correcting the trouble, push in the reset button.

(3) If the machine will still not start, check the transformer. Replace the transformer if necessary. Test operate to ensure that the problem has been eliminated.

b. *Troubleshooting the Malfunction: MACHINE VIBRATION.* Machine vibration may be the result of the presence of either of two conditions.

(1) The band wheels may have become unbalanced. Check to see if the band wheels are balanced.

(2) If the band wheels are balanced, and vibration is still present, it is possible that the drive belts may have been replaced by belts which are unbalanced. Balance the drive belts, as required, then test operate to ensure that the malfunction no longer exists.

c. *Troubleshooting the Malfunction: SAW BAND VIBRATION DURING SAWING.* When saw band vibration occurs during sawing operations, make these checks:

(1) Check the band speed and the feed force. Saw band vibration can be caused by the selection of the incorrect band speed or by the incorrect feed pressure. Make adjustments as needed to correct the problem.

BANDSAW OPERATIONS - OD1646 - LESSON 2/TASK 2

(2) If the band speed and feed are correct, the pitch of the saw blade may be incorrect. Check the pitch of the saw blade, and select a blade of the proper pitch, if required.

(3) Saw band vibration can occur if the workpiece is not firmly clamped to the table. If this is the case, adjust the clamps to solve the problem.

(4) Worn or improperly adjusted saw guide inserts can cause saw band vibration. Adjust or replace the saw guide inserts, as required.

(5) A worn saw guide backup bearing could be causing the problem. Check the saw guide backup bearing and replace it, when needed.

d. *Troubleshooting the Malfunction: SAW BAND IS CUTTING INACCURATELY.* When the saw band is cutting inaccurately, a number of conditions could be responsible for the trouble.

(1) First, check for worn blade teeth. Replace the blade if the teeth are worn. Then test operate to see if the problem has been solved.

(2) If the scale on the workpiece has not been removed, inaccurate cuts will result. Remove the scale from the workpiece, if needed.

(3) The blade in use may be too wide for the radius being cut. Check the blade width, and select a more appropriate blade, if necessary.

(4) The saw band or the insert may be improperly aligned. Make the needed alignments, and test operate to see if the problem has been fixed.

(5) Using either the incorrect feed force or the incorrect band speed can cause inaccurate cuts. Adjust the feed force and/or the band speed, as needed, to correct the problem.

(6) If coolant is not applied evenly to both sides of the saw band, inaccurate cuts may result. Check for this condition and correct it, if necessary.

BANDSAW OPERATIONS - OD1646 - LESSON 2/TASK 2

(7) If the saw guide on the upper post is not located close enough to the workpiece, inaccurate cuts may result. Adjust the position of the saw guide, if needed.

(8) Inaccurate cuts can also result from incorrect saw band tension. Check the band tension and adjust it, as needed.

e. *Troubleshooting the Malfunction: EXCESSIVE INSERT AND BLADE WEAR.* When there is excessive insert and blade wear, make these checks:

(1) Check to see if the inserts are adjusted too tightly on the blade. Make any needed adjustments.

(2) The chip brush may be worn, or may not be adjusted properly, allowing the chips to stay on the wheel. Check for this condition, and make the necessary repairs.

f. *Troubleshooting the Malfunction: FILE BAND BREAKS.* When the file band breaks, two conditions could be the cause:

(1) The feed force may be too high. Adjust the feed force to solve the problem.

(2) The wrong type of file band may be in use. Make sure that the file band meets all the requirements for filing the material in the workpiece.

g. *Troubleshooting When There is a POOR FINISH FROM BAND FILING.* A poor finish from band filing could be the result of any of the following conditions:

(1) The feed force could be too high. Reduce the feed force, as needed.

(2) The file band may not be assembled correctly.

(3) The band tension may be too high. Set the band tension at the setting used for a 1/8 inch wide carbon band.

h. *Troubleshooting When the SURFACE FINISH ON THE WORK IS TOO ROUGH.* When the surface finish on the workpiece is too rough, any of following could be the cause. Check for the presence of one of these

BANDSAW OPERATIONS - OD1646 - LESSON 2/TASK 2

five conditions, and make corrections or adjustments, as needed:

- (1) The saw guide inserts may be worn. Readjust them, as needed.
- (2) The saw band speed may be too low.
- (3) The saw band pitch may be too coarse.
- (4) The feed may be too heavy.

(5) Vibration could cause this condition. The troubleshooting procedures used to solve vibration problems can be found in paragraphs 4b and 4c, beginning on page 75.

i. *Troubleshooting the Malfunction: PREMATURE DULLING OF SAW BAND TEETH.* Premature dulling of the saw band teeth may be caused by any of these conditions:

(1) The saw band must be broken in on the first few cuts by using a reduced feed pressure and speed. If the saw band is not broken in this way, premature dulling of the saw band teeth can occur.

(2) The band speed may be too high causing abrasion. Reduce the speed, as needed.

(3) The saw band pitch may be too coarse. Choose a band with a finer pitch.

(4) The feed pressure may be too light. Increase the feed pressure as needed to solve the problem.

(5) The coolant may not be covering the saw band. Make adjustments, as needed.

(6) The cutting rate may be too high.

(7) There may be a fault in the material being cut, such as a heavy scale, inclusions, or hard spots.

(8) Saw band vibration can cause premature dulling of the blade. Troubleshooting procedures to solve saw band vibration problems can be found in paragraph 4c, beginning on page 75.

BANDSAW OPERATIONS - OD1646 - LESSON 2/TASK 2

(9) If a chipped tooth is lodged in the cut, the saw blade will dull prematurely.

(10) Chip welding can also cause premature dulling of the blade.

(11) If the inserts are too large for the blade width, the inserts may hit the set teeth, causing the blade to dull prematurely.

j. *Troubleshooting the Malfunction:* BAND SLIPS OFF THE WHEELS. Two conditions could cause the band to slip off the wheels:

(1) The upper wheel may not be aligned correctly, so that the band does not track on the center of the wheel tire. Adjust the track of the band, if needed, so that it tracks on the center of the wheel tire.

(2) The initial machine alignment may be wrong. When this is the case, refer to TM 9-3419-228-10, page 2, for the procedure needed to solve the problem.

5. Troubleshooting Fault Symptoms in the Model 2614-1 Bandsaw Machine

Fault symptoms and their possible causes for problems in the model 2614-1 bandsaw machine are described below. As stated earlier, the specific repairs needed to eliminate these malfunctions will not be discussed in detail here. Operational solutions to problems, such as adjusting the saw guides, can be found in TM 9-3405-210-14&P, pages 5 through 15. Lubrication and maintenance solutions for malfunctions can be found in TM 9-3405-210-14&P, on pages 15 through 18. This TM should always be used as a reference when actual repair or troubleshooting procedures are performed.

a. *Troubleshooting the Malfunction:* MACHINE WILL NOT START. When the model 2614-1 bandsaw machine will not start, make these three checks to isolate the cause of the problem:

(1) First, check the main fuses and the control circuit fuse. Any fuse that is defective should be replaced. If a fuse is replaced, try to start the machine to see if the problem has been solved.

BANDSAW OPERATIONS - OD1646 - LESSON 2/TASK 2

(2) If all the fuses are operational, but the machine will not start, check the reset on the band drive motor starter (if a starter is used). Starting and stopping the machine a number of times in quick succession, or an overload, will trip the starter heater. After locating and correcting the trouble, push in the reset button. If the heater relay has been set for automatic operation, it will not be necessary to push the reset button, but will only be necessary to wait for the relay to cool. Then try starting the machine to see if the malfunction is still present.

(3) If the malfunction is still present, check the transformer, and replace it, if necessary. Test operate to ensure that the problem has been fixed.

b. *Troubleshooting the Malfunction:* SEVERE MACHINE VIBRATION. Three conditions could cause severe machine vibration.

(1) If the band wheels are not balanced, machine vibration could result. Check to see if the band wheels are balanced.

(2) If the band wheels are balanced, and vibration is still present, check to see if the variable pulley components are balanced. If they are not balanced, vibrations could result. Balance the components of the variable pulley, if needed. Then test operate to see if the trouble has been fixed.

(3) If severe machine vibration is still present, check to see whether the variable drive belts are unbalanced. Balance the drive belts, if required, then test operate to ensure that the malfunction is no longer present.

(4) Severe machine vibration can result if the bandsaw machine is not resting evenly on the floor. To correct this condition, refer to the alignment procedure in TM 9-3405-210-14&P, page 1.

c. *Troubleshooting the Malfunction:* SAW BAND VIBRATION DURING SAWING. When saw band vibration occurs during sawing operations, make these checks:

(1) Check the band speed. Saw band vibration can be caused by the selection of the incorrect

BANDSAW OPERATIONS - OD1646 - LESSON 2/TASK 2

band speed. Adjust the band speed, as needed to correct the trouble.

(2) If the band speed is correct, the pitch of the saw blade may be incorrect. Check the pitch of the saw blade, and select a blade of the proper pitch, if required.

(3) If a blade with the proper pitch is in use, but saw band vibration is still present, the choice of coolant may be incorrect. Select the proper coolant to solve this problem.

(4) If the coolant being used is correct, it is possible that the feed pressure is incorrect. Vary the feed pressure to see if this is causing the trouble.

(5) Severe saw band vibration can occur if the work piece is not firmly clamped to the table. If this is the case, adjust the clamps to solve the problem.

(6) Worn or improperly adjusted saw guide inserts can cause saw band vibration. Adjust or replace the saw guide inserts, as required.

(7) A worn saw guide backup bearing could be causing the problem. Check the saw guide backup bearing and replace it when needed.

(8) When the heavy work slide or the heavy work clamp is used, special support must be used under the workpiece. If special support is not used, saw band vibration could result.

d. *Troubleshooting When There is NO COOLANT FLOW.* If there is no coolant flow, check for the presence of one of these conditions and remedy the situation as required:

(1) Check to see if the coolant applicator nozzle is jammed.

(2) Check to see if the coolant hose is clogged or kinked.

(3) Check to see if the coolant reservoir is empty.

e. *Troubleshooting When the SURFACE FINISH ON THE WORK IS TOO ROUGH.* When the surface finish on the

BANDSAW OPERATIONS - OD1646 - LESSON 2/TASK 2

workpiece is too rough, then any of the following conditions could be the cause. Check for these five conditions, and make corrections or adjustments as needed:

(1) The saw guide inserts may be worn. Readjust them, as needed.

(2) The saw band speed may be too low. Adjust the band speed as needed to eliminate the problem.

(3) The saw band pitch may be too coarse. Choose a saw band with a finer pitch.

(4) The feed may be too heavy. Adjust the feed as required to eliminate the problem.

(5) Vibration could cause this condition. See paragraphs 5b and 5c, beginning on page 80, for the troubleshooting steps performed to solve vibration problems.

f. *Troubleshooting the Malfunction: SAW BAND TEETH STRIPPING.* Saw band teeth stripping is usually caused by chip welding. It may also be caused by the following:

(1) The saw band pitch may be too coarse for a thin work section.

(2) The workpiece may not be held firmly enough to stop vibration.

(3) The feed pressure may be too high. Adjust the feed pressure as needed to eliminate the symptom.

(4) The band speed may be too low. Raise the band speed slightly to eliminate the problem.

g. *Troubleshooting the Malfunction: PREMATURE DULLING OF SAW BAND TEETH.* Premature dulling of the saw band teeth may be caused by any one of the following conditions:

(1) The saw band must be broken in on the first few cuts, or premature dulling of the saw band teeth could occur. Break in the saw band by using a reduced feed pressure and speed on the first cuts.

BANDSAW OPERATIONS - OD1646 - LESSON 2/TASK 2

(2) The band speed may be too high, causing abrasion. Reduce the saw band speed as needed.

(3) The saw band pitch may be too coarse. Choose a band with a finer pitch.

(4) Premature dulling of the saw band teeth can occur if the wrong type of coolant is used, or if no coolant is used.

(5) The feed pressure may be too light. Increase the feed pressure, as required to eliminate the problem.

(6) The coolant may not be covering the saw band. Make adjustments as needed.

(7) The cutting rate may be too high.

(8) The material being cut may have faults, such as a heavy scale, inclusions, or hard spots.

(9) The material analysis may be incorrect.

(10) Saw band vibration can cause premature dulling of the blade. To eliminate saw band vibration, perform the troubleshooting steps listed in paragraph 5c, starting on page 80.

(11) If a chipped tooth is lodged in the cut, the saw blade will dull prematurely.

(12) Chip welding can also cause premature dulling of the blade.

(13) If the inserts are too large for the blade width, the inserts may hit the set teeth, causing the blade to dull prematurely.

h. *Troubleshooting the Malfunction:* MOTOR RUNS BUT THE BAND DOES NOT MOVE. Several conditions could cause the band to remain stationary even when the motor is running.

(1) The drive belts could be broken, or they may be off the pulleys. Replace or adjust the belts as needed.

(2) Too much oiling of the variable pulley may have caused the pulley (and subsequently the belts) to be coated with oil, causing the belts to slip.

BANDSAW OPERATIONS - OD1646 - LESSON 2/TASK 2

(3) The drive belt tension may be too low. Adjust the tension on the drive belt, as needed.

(4) Using the wrong size of drive belt can also cause this problem.

(5) If the band tension is incorrect, the motor could run while the band remained stationary.

(6) It is also possible that the transmission could be bad. It is recommended that a faulty transmission be returned to the factory for repairs.

i. *Troubleshooting the Malfunction: BAND SLIPS OFF THE WHEELS.* Three conditions could cause the band to slip off the wheels:

(1) The upper wheel may not be aligned correctly, so that the band will not track on the center of the wheel tire. Adjust the wheel tilt, if needed, so that the band tracks in the center of the wheel tire.

(2) Too much coolant or the wrong type of coolant can cause the band to slip off the wheel tires.

(3) The initial machine alignment may be wrong. When this is the case, refer to TM 9-3405-210-14&P, page 1 for the procedure needed to solve the problem.

6. Conclusion

The procedures for troubleshooting malfunctions in the three models of bandsaw machines described in this subcourse are similar. This task has introduced you to these procedures. Remember that the appropriate TM should always be used as a reference when actually performing the troubleshooting procedures on the bandsaw machine.

PRACTICAL EXERCISE 2

1. Instructions

Read the scenario and respond to the requirements that follow the scenario.

2. Scenario

You are now fairly confident that the Saudi representative knows enough about bandsaw operation. However, you need to be sure that the bandsaw machines can be maintained properly, and that the Saudi personnel can perform troubleshooting on the machines, should problems arise.

3. First Requirement

Many of the maintenance procedures for the various models of bandsaw machines are similar, or the same for all models. Some procedures, however, are specific to only one model. You have prepared an outline covering the maintenance procedures which apply to the models of the bandsaw machine available to the Saudis. Each question below is based on that outline. Answer each question correctly.

- a. What must be done if a wheel brush is worn so that it is not longer contacting the wheel face?
- b. What type of lubricant should be used on the wheel bearings?
- c. What could result if the faces of the variable speed pulley are scored?
- d. How is the center sheave of the variable speed pulley lubricated?
- e. Briefly describe the procedure for replacing a wheel tire on the model 2612-1M bandsaw machine.
- f. What is used to lubricate the air pump on the model 1612-0 bandsaw machine?
- g. Describe the position of the motor bracket on the model 1612-0 bandsaw machine when the bracket is properly adjusted.

BANDSAW OPERATIONS - OD1646 - LESSON 2/PE 2

4. Second Requirement

The Saudi representative has had his people operating the bandsaw machines for practice. They have encountered some problems. This provides an excellent opportunity to introduce some of the procedures for troubleshooting.

a. One operator has had problems operating the model 1612-0 bandsaw machine. The saw band keeps vibrating during the sawing operations. Describe the procedures that should be used to troubleshoot for this symptom.

b. Another operator has been working on the model 2614-1 bandsaw machine. The band keeps slipping off the wheels. Describe the procedure used to isolate the cause of this problem.

LESSON 2. PRACTICAL EXERCISE - ANSWERS

1. First Requirement

- a. Loosen the adjusting screws and move the brush up to the wheel.
- b. None. The wheel bearings are sealed and lubricated for life.
- c. The belts could be damaged.
- d. The center sheave of the variable speed pulley is lubricated by a wick which is immersed in oil.
- e. To replace a wheel tire on the model 2612-1M bandsaw machine, remove the two retainers from the front of the band wheel. Then remove the tire retaining rings. Drive the tire off the wheel, sawing off the steel backing, if necessary. Mount a new tire so that the two notches in the steel backing are in alignment with the two tire retainers. Put the new tire on with light taps of a soft-faced hammer, rotating the wheel about 30 degrees as each tap is made, until the tire is against the flange of the wheel.
- f. Powdered graphite is used very sparingly to lubricate the air pump.
- g. The bracket, when properly adjusted, will just clear the motor plate when it is at its highest position during operation.

2. Second Requirement

- a. When saw band vibration occurs during sawing operations on the model 1612-0 bandsaw machine, these checks should be made:

(1) Check the band speed. Saw band vibration can be caused by the selection of the incorrect band speed.

(2) If the band speed is correct, the pitch of the saw blade may be incorrect. Check the pitch of the saw blade, and select a blade of the proper pitch, if required.

(3) If a blade with the proper pitch is in use, but severe saw band vibration is still present, the

BANDSAW OPERATIONS - OD1646 - LESSON 2/PE 2

choice of coolant may be incorrect. Select the proper coolant to solve this problem.

(4) If the coolant being used is correct, it is possible that the feed pressure is incorrect. Vary the feed pressure to see if this is causing the trouble.

(5) Severe saw band vibration can occur if the work piece is not firmly clamped to the table. If this is the case, adjust the clamps to solve the problem.

(6) Worn or improperly adjusted saw guide inserts can cause saw band vibration. Adjust or replace the saw guide inserts, as required.

(7) A worn saw guide backup bearing could be causing the problem. Check the saw guide backup bearing and replace it, when needed.

(8) When the heavy work slide or the heavy-work clamp is used, special support must be used under the workpiece. If special support is not used, saw band vibration could result.

b. Three conditions could cause the band to slip off the wheels on the model 2614-1 bandsaw machine:

(1) The upper wheel may not be aligned correctly, so that the band will not track on the center of the wheel tire. Adjust the wheel tilt, if needed, so that the band tracks in the center of the wheel tire.

(2) Too much coolant or the wrong type of coolant can cause the band to slip off the wheel tires.

(3) The initial machine alignment may be wrong. When this is the case, refer to TM 9-3405-210-14&P, page 1 for the procedure needed to solve the problem.

REFERENCES

BANDSAW OPERATIONS - OD1646 - REFERENCES

REFERENCES

The following documents were used as resource materials in developing this subcourse:

TM 9-3405-210-14&P
TM 9-3419-227-10
TM 9-3419-228-10
FM 9-24