

A simple lathe countershaft unit

H. D. BOND describes a method of saving workshop space and providing a self-contained motorised unit

THE fitting illustrated in the drawings was made to suit a 3-1/2 in. Drummond type lathe which had previously been driven from an overhead countershaft and lineshaft, and its main object was to save workshop space and provide a self-contained "motorised" unit. It was built up mainly from stock mild steel bar and plate material, fastened with bolts and Allen screws.

The largest item is the backplate, A, which was cut from 3/8 in. mild steel plate 11 in. long x 6 in. wide. Six holes 1/4 in. clearing were drilled for the attachment of the bearing pedestals, and four holes of the same size were drilled through the lower end to take the hinge lugs. These parts were held on by Allen screws.

Item B, the baseplate, is also made from 3/8 in. mild steel plate 8 in. x 3 in. wide. This is drilled with four 1/4 in. clearing holes for the hinge lugs and two 5/16 in. holes for the lever pedestal. Two slots 1-1/2 in. long x 1/4 in. wide were cut in the plate to allow of belt tension adjustment.

Bearing pedestals

The bearing pedestals, C, were made from 1/2 in. mild steel plate 5 in. long x 2-1/2 in. wide, one end of which was machined square; and at 3-3/4 in. from this surface the bearing centre was marked off, centre-punched, then set up on the faceplate with the aid of a wobbler and dial gauge. It was then bored through 1 in. dia., and counterbored to take a standard ball race 1-3/4 in. dia. x 3/8 in. deep. Each of these housings was then fitted with an end plate, D, made from 1/2 in. mild steel plate. This was bored 1 in. dia. with a shallow spigot to fit bearing housing and attached by means of four 6 BA screws.

The lever pedestal, E, which is of mild steel bar, 6 in. x 1-1/4 in. x 1-1/2 in., is faced at both ends, the lower end being drilled and tapped 5/16 in. BSF for attachment to baseplate. A hole 1/2 in. dia. is drilled and reamed to take the cam spindle, and a hole is drilled and tapped 1/4 in. BSF in the top end for attachment to return spring.

The lugs K and L (two-off each), attached to parts A and B respectively, are fitted with a 7/16 in. mild steel bar

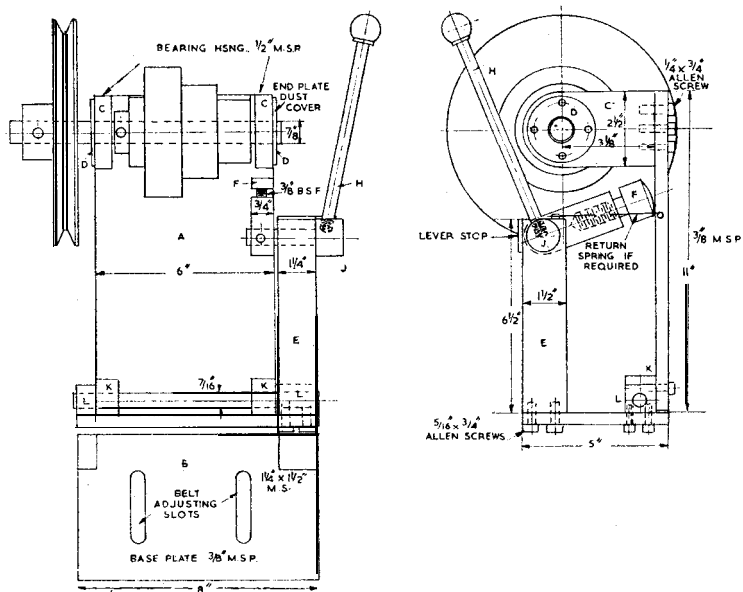

which forms a hinge pin, thus allowing the entire backplate and bearing housing to swing freely about this point. Its movement is controlled by a thrust member with a screwed adjustable head, F, which is mounted on the cam spindle, J, and acts as a toggle against the face of the backplate A.

The ball-ended lever H is made of

a length to suit the convenience of the user, and is screwed 3/8 in. dia. at the lower end to fit the cross-hole in J. The stop-plate is attached by two 4 BA screws to the front face of the lever pedestal E to limit the forward movement of the lever, and where the position of the unit makes it desirable, a return spring can be fitted between the lever pedestal and the backplate. □

