

HORIZONTAL SURFACE GRINDING AND MILLING MACHINE

By R. Hamilton

IT will be generally accepted? I think, that a machine combining the functions of milling and surface grinding, would be very useful in the small workshop and enable the amateur to impart a precision and finish to items, otherwise difficult to achieve. With such a consideration in mind, I commenced, about a year ago, the construction of such a machine and now have it in satisfactory use.

The following notes and drawings may interest readers who wish to add to their equipment but find the costs of purchasing too heavy.

No castings are employed ; the entire machine is fabricated in steel, picked from scrap. The only parts purchased were pulleys, two Myford gear wheels (30 and 60 teeth), two bearing blocks and elevating screw hand-wheel. My outlay was under £6, including the cost of welding.

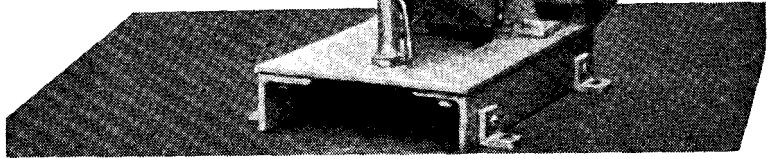

All machining was done on a M.L.7 lathe, excepting the shaping of column and surface grinding of parts. Access to a shaper and grinder was provided by a friend. As most readers require no instruction from me in the general aspects of setting-up, turning, etc., I shall not attempt to elaborate.

For convenience, the construction is set out under the following heads : 1. Base and column ; 2. Knee, cross traverse and table ; 3. Spindle, overarm and bracket, arbors and elevating screw ; 4. Pulley arrange-

ment, backgear, countershaft, also sundry items and comments.

The drawings are self-explanatory; a few parts, such as handles, rack, cross traverse feedscrew, etc., being omitted. Potential constructors will suit themselves as to dimensions of parts ; mine were conditioned by the machining limits of the M.L.7. A good deal of hacksawing is involved, but this can be spread over.

Base and Column

The base is a 1/4 in. thick plate screwed from the underside to heavy angle iron sides, to which holding down lugs are attached. Below the column is strongly reinforced by a heavy channel iron piece which is welded to platform and sides. The horizontal webs of angle iron, it will be noted, are sufficiently cut away to allow flush fitting of channel piece. The opening in the platform allows the knee to sink somewhat below the shear limit, an advantage when the awkward job comes along.

The column (in my case) was shaped from a solid steel block I had handy, and surface ground all over. As the column is bound to present difficulty to most constructors, I would mention in passing, the feasibility of a fabricated hollow column made from two lengths of channel iron locked by two heavy plates, the front one of which could have the vees machined on it. The width of such a column would allow the fitting of taper roller bearings. Drilling, boring and tapping were routine jobs. Holes for bracket screws were marked off from completed brackets. Note that the spindle hole is opened up

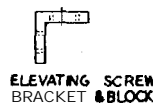
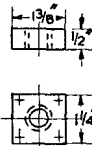
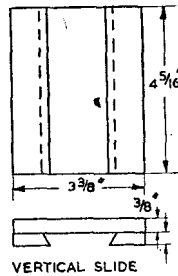
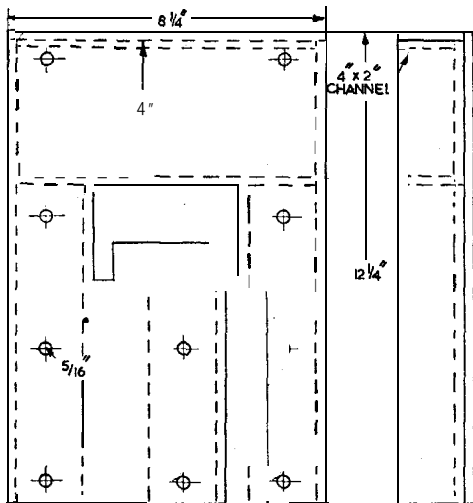

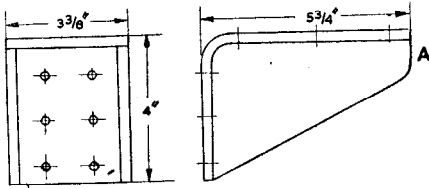

KNEE

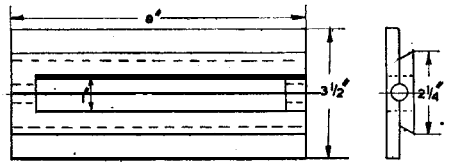
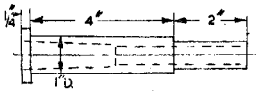
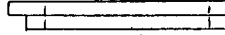
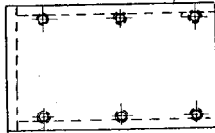
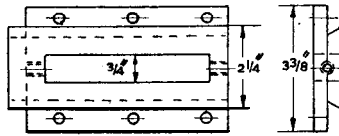

TABLE LOWER SLIDE



SPINDLE



CROSS TRAVERSE LOWER SLIDE

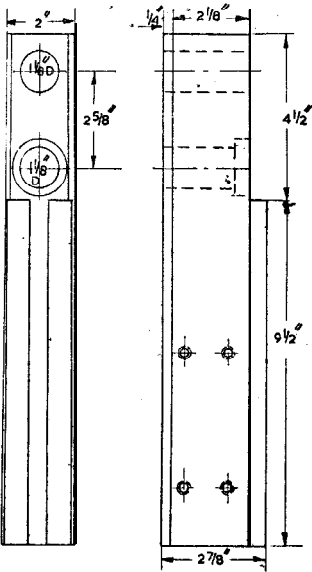

COLUMN

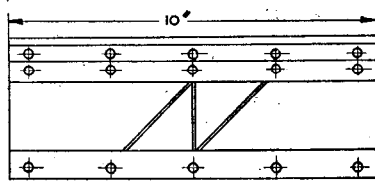
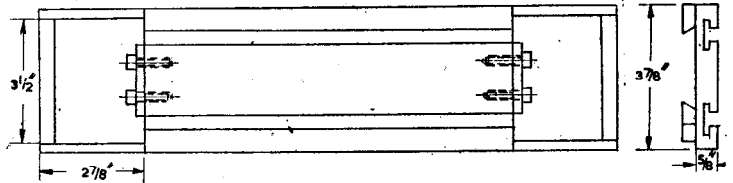
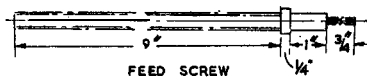
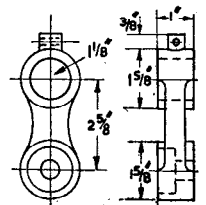

TABLE & TRAYS



FEED SCREW



OVERARM BRACKET



35 TEETH
RACK PINION

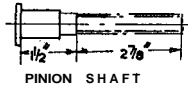

PINION SHAFT

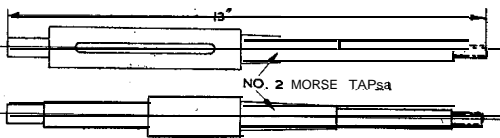

ARBORS

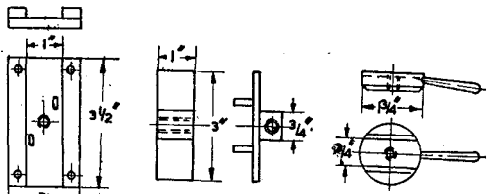

CLASP NUT & CAM ASSEMBLY

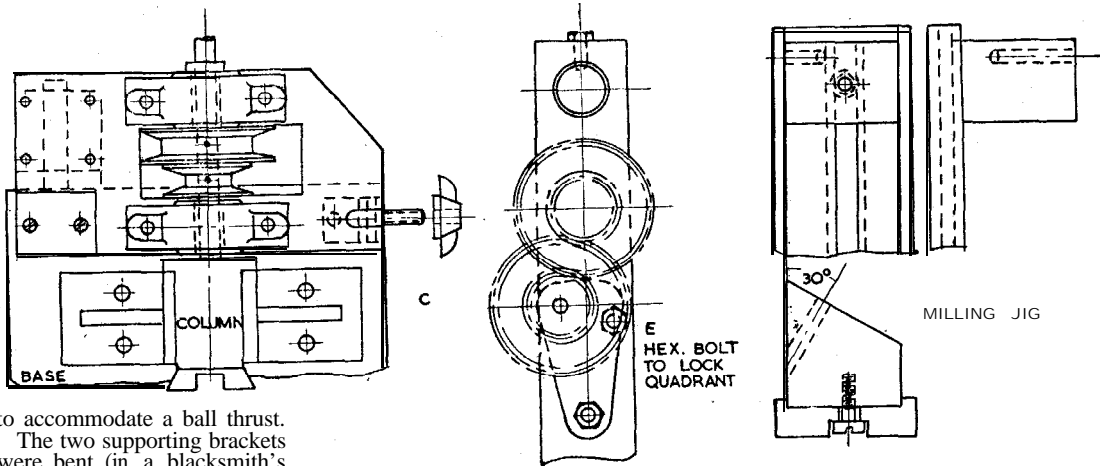

to accommodate a ball thrust.

The two supporting brackets were bent (in a blacksmith's bending machine) from 1/4 in. thick flat plate and machined webs welded in place. A little tiling and scraping secured good seating on both faces, which is essential to avoid strain on base and column. Countersunk screws had to be used in two holes of the right-hand bracket to allow clearance for elevating feedscrew block.

Knee, Cross-traverse and Table

The knee was also bent from flat and machined sides welded on. It was set up on the lathe table and edge marked A milled. Then the horizontal platform was placed on the table with the A edge lined up parallel with the table rear edge, and the vertical platform machined by feeding it across a tool suitably offset in chuck. This face was next bolted to an angle-plate, set parallel with lathe axis (the A edge providing vertical alignment check) and the long face likewise machined. The

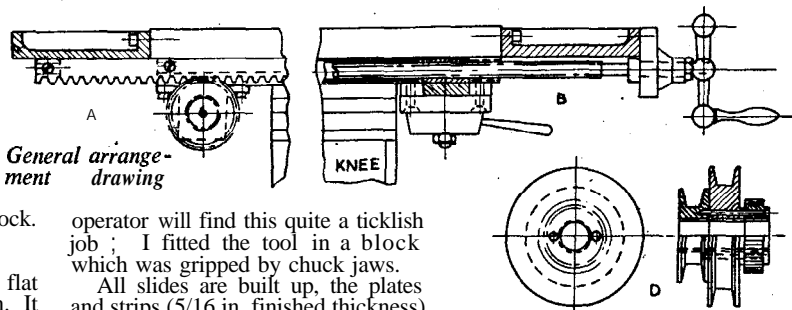

operator will find this quite a ticklish job; I fitted the tool in a block which was gripped by chuck jaws.

All slides are built up, the plates and strips (5/16 in. finished thickness), being first ground *on* inner faces before countersunk riveting them together, to prevent warping, then ground on outer faces. Uniformity of vee-angles on plates and strips was obtained as follows: A jig (as shown) was made and plates screwed down thereon and end milled. The jig was lined up with the table front edge, packed up as required, and the angle blocks moved apart to suit varying lengths. The holes in

The completed cross traverse and vertical-slides were secured to the knee by cap screws.

The table was -quite a job, due to its size. After facing both sides and end milling to square, it was clamped to a long, broad and heavy angle-iron which was bolted to the lathe table, the whole assembly overhanging the front of the slide with the lower edge of the workpiece

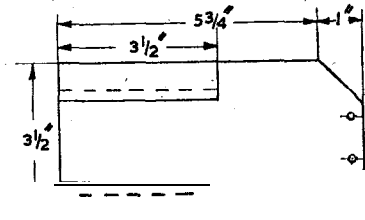
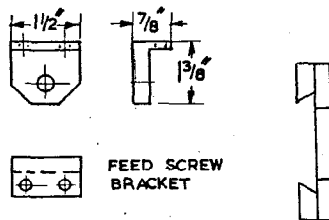
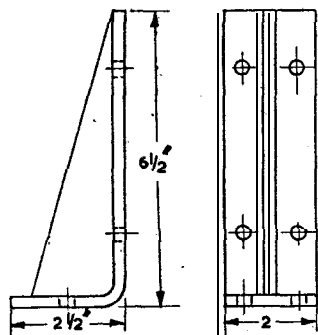

CROSS TRAVERSE TOP SLIDE

plates were plotted, as far as possible, to be used in assembly. Strips were actually cut off from plates, after milling. Additional cross-slide traverse was obtained, when required, by insertion of accurate distance pieces between cross-slide face and bracket) and cuts made in stages without disturbing the workpiece.

just clearing the bed. Thus the "T" slots were milled out, again in stages. But for this operation I was compelled to slide the whole assembly over the table to clear *the* cut, a check bar lying against the angle-iron rear edge preserving alignment.

(To be concluded)

Horizontal Surface Grinding and Milling Machine

By R. Hamilton

THE trays were fashioned from suitable channel iron, webs cut down, and faced in lathe. The radius on one of the webs was removed by end milling. Side pieces to trays were screwed in place by B.A. countersunk screws.

Clasp nut and guide assembly were screwed into position (see General Arrangement B), then the holes through table under slide and nut drilled in one operation,

Concluded from page 268, August 27, 1953.

the hole in the slide end being amply opened up to clear the feedscrew. Another hole, in axial alignment, is drilled in the opposite end of the slide. This is to permit the free passage of the long feedscrew, which travels with the table and to act as a housing for the after end of the brass tube which retains the feedscrew in its normal axis when the clasp nut is open for grinding operations. The clasp nut is actuated exactly as on the M.L.7, except that the guide is square sided and not veed. Slitting of the nut was left

till the cam assembly had been fitted, which simplified the lining up of nut studs and cam slots. Studs are of silver-steel.

The rack pinion and housing parts need no comment (see General Arrangement "A"). The housing is bushed and oilwayed. The handle not shown, pulls off when not in use, by slackening a 3/16 in. Allen screw.

Locking levers are fitted to vertical- and cross-slides; a long cap screw serves this purpose on table-slide. A ram-like support (see photographs) counters any tendency of the knee to dip under load. A hole requires to be drilled in the platform to allow the plunger to pass through. A flat on the plunger takes any bruising by locking the lever point.

When throwing the table during grinding, the clasp nut being open, the feedscrew would wobble and foul unless retained in its normal path in some way. I got over this difficulty as follows: A brass tube, mentioned above, with an I.D. just sufficient to accommodate the 3/8 in. feedscrew, has one end housed in the hole at the after end of the slide. The other end, very slightly bell-mouthed, is soldered to a brass cradle which is screwed to nut guide and just clears the rear face of the nut (see General Arrangement B, "in which the tube is shown" in heavy black). The idea works very well and does no damage to the screw.

The rack was cut on the lathe as follows: Two 1 1/4 in. (or thereabout) broad plates, 5/16 in. thick, each fractionally over half rack length, were bolted together to an angle-plate, being packed off the angle-face by about 1 in. Angle-plate was set on table, parallel with and behind lathe axis. A 1 1/4 in. diameter cutter was made, with a tooth formation to fit lathe rack and mounted on a mandrel between centres. The plates were packed up so that tooth depth was cut at one pass. An indexing device was made, consisting of a small block to which was screwed a short stiff rod, the end of which was filed to tooth shape. The device was placed on thread dial indicator

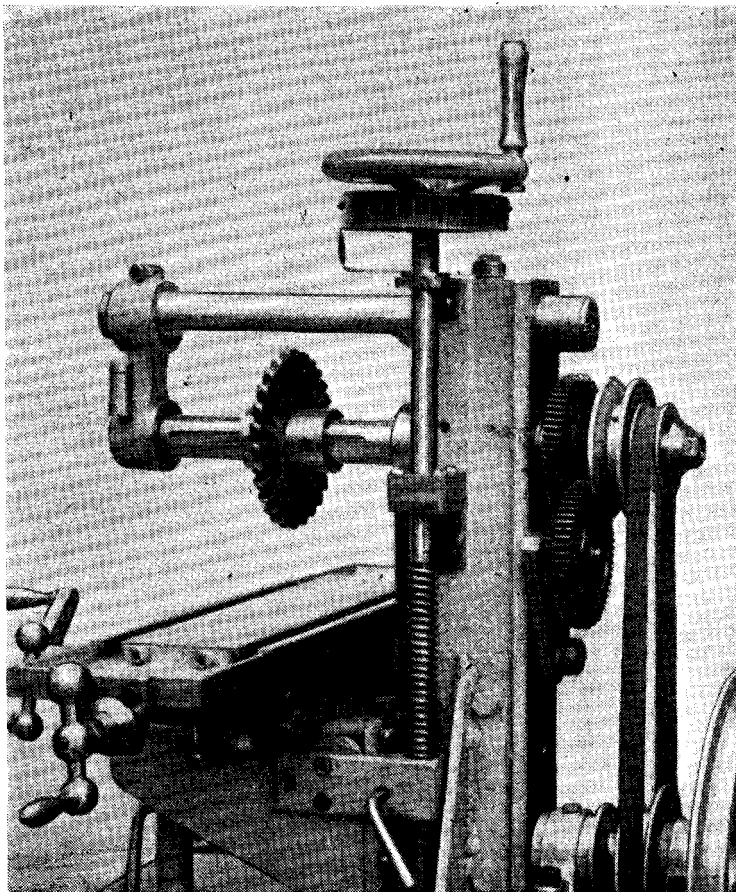

The machine set up for horizontal milling.

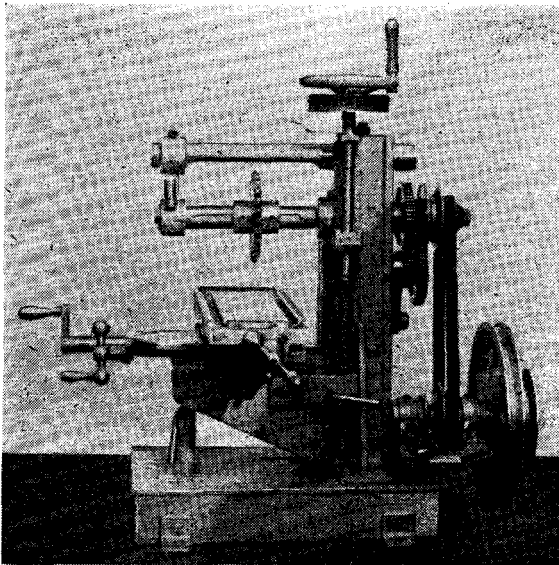

(Left). Side view of complete machine.

stud. When pivoted forward, the shaped point engaged a rack tooth. Saddle was locked and a cut made. And so on. Two strips were cut off plates and cleaned up. After screwing rack into place, the four holes to take table gib strip adjustment screws were drilled through rack and fixed strip in one operation. The rack is anchored to left-hand tray by a small bracket.

Spindle, Overarm and Bracket, Arbors and Elevating Screw

Drawings of spindle, overarm and arbors explain themselves. All were ground finished on lathe. As can be seen, a close fitting dirt excluding cover is fitted at spindle front and another can be pushed on to bracket to protect the ball thrust and race, most important requirements when grinding. Spindle bush is of gunmetal. It is cross-slotted down to centre-line a third way in from each end with lengthwise slots on top breaking in. A somewhat queer design, readers will comment, but it gives no trouble. Adjustment is by set screws through column side. It is also oilwayed. Overarm bracket was machined on lathe (a faceplate job) as far as possible and finished by filing. A ball thrust and race combined is inserted in bracket and a gunmetal bush also fitted to act as a steady. Lubrication cups are fitted, as shown on photographs. Milling arbor is keywayed and cutter retaining collars ground on faces at right-angle to bore. This simple method of locating cutters has proved effective. Grinding wheel, with its two large collars, is locked

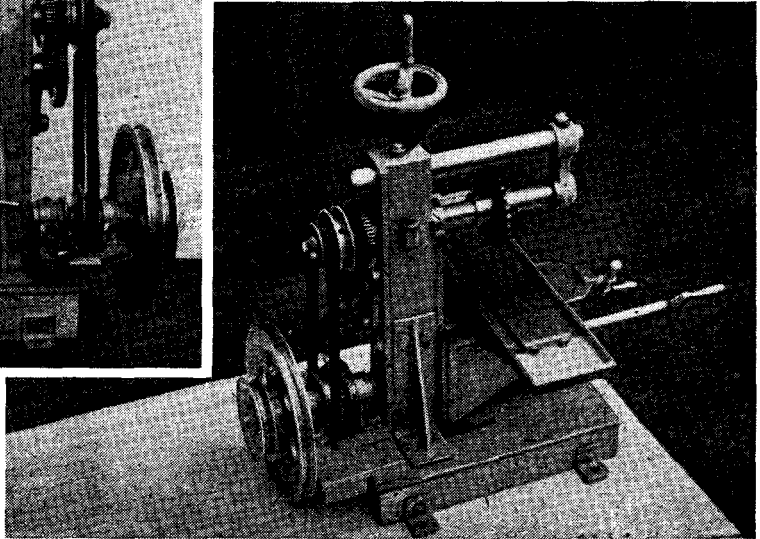

(Below). A view from a high level at the rear.

against the shoulder of its arbor by a screwed sleeve and nut, Allen-keyed to a filed flat on arbor. Sleeve is a gas pipe union cut down. Elevating screw is in two parts, locked together by a push-out silver steel pin. Oilways are cut in collar and an oil hole drilled in collar block. Collar block bracket and top supporting bracket are made from angle-iron and on former, both faces are carefully finished so that collar bears down perfectly. Cross traverse and elevating feed-screw nuts are replaceable.

Having no dividing head (yet), I hand-calibrated the elevating screw index thus: A black coloured aluminium strip (10 5/16 in.) long, was pinned to a flat board and a 12-in. rule likewise pinned against its lower edge. Using a small square I scribed each 1/18 in., grouping every five and ignoring the odd one. The strip was pinned to a disc turned to suitable size. As an improvisation it will serve till I have a dividing head. The pointer is held in place by the hexagonal-headed screw which locks the overarm.

Pulley Arrangement, Backgear, Countershaft and Sundry Items

General arrangement drawings C, D and E more or less remove the need for any comments in respect

of the pulley drive, countershaft and backgear layouts. Bull wheel (60-teeth) is pitted to a steel boss and Allen-keyed to spindle. direct drive, pulley cluster is locked to spindle by an Allen key, the point of which enters a small groove to prevent bruising. Backgear wheels, separated by a thin washer, slide on to a shouldered bush and are key-coupled. A projecting pin on quadrant, striking column edge, prevents over-meshing. The primary drive pulleys are mounted on the overhanging shaft. The backgear and rack pinions can be removed in a few seconds, when required for use on lathe.

The 8-in. pulley is used for milling, and when grinding, a separate belt is placed on the 4 in. one. A 1/4-hp. motor (1,440 r.p.m.), has a 134-in. milling and a 4-in. grinding pulley.

Milling speeds: 52, 118, 210 and 412. Backgear 4 to 1.

Grinding speed: 2,160-secondary drive 3 in. to 2 in.

Vibration has not troubled me, nor has overheating appeared at grinding speed. Before grinding, however, I run machine at 210 r.p.m. for a time to warm it up. I think a 1/3-h.p. motor would be more suitable and maybe I shall fit one some day. Milling cuts can be taken quite heavily, depending, of

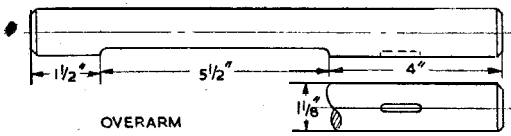

OVERARM

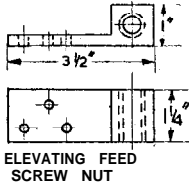

ELEVATING FEED SCREW NUT

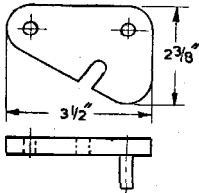

BACKGEAR QUADRANT

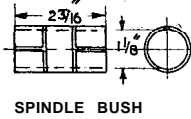

SPINDLE BUSH

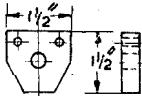

FEED SCREW BRACKET

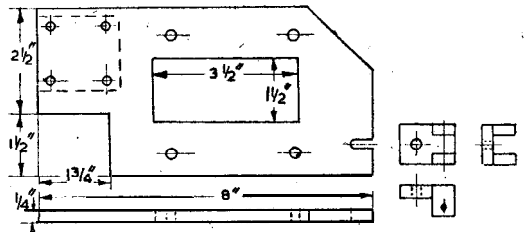

PIVOTING COUNTERSHAFT PLATE & PARTS

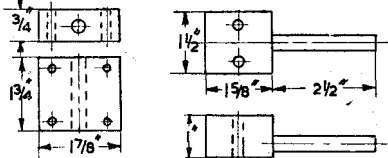

ELEVATING SCREW

course, on type of cutter and speed used.

In the course of making such a machine as this, any constructor, who is limited in the equipment at his disposal, as I was, will find that

a considerable amount of extemporising, jiggging and what not, will be called for; many difficult moments have to be faced and trouble overcome. Sometimes my set-ups had the appearance of a "Heath-

Robinson" cartoon. But I can assure my readers that I enjoyed every moment and have no regrets.

The photographs accompanying this article are by J. S. O'Neil, Old Kilpatrick, by Glasgow.

AN EFFECTIVE, SOLDER FOR ALUMINIUM

VERY frequently the model engineer requires to solder parts in aluminium, in either its sand-moulded cast state, or the usual drawn or rolled sheet forms. This operation is usually attended by considerable difficulties, since ordinary solders and methods are of little practical use.

In view of the well-known objections, aluminium is usually regarded as non-solderable; but the difficulties can be satisfactorily overcome, with little expense or trouble, by using a solder according to the following composition.

Take three parts of pure zinc and one part of block tin (by weight). The zinc should preferably be taken from a cast ingot of virgin metal, where possible, to ensure purity and cleanliness. Scrap zinc articles should not be melted down for this purpose, since a certain degree of contamination or deterioration cannot be avoided.

The zinc is first melted in an ordinary hand-ladle over a bunsen jet or oxy-acetylene torch, and the tin added. The molten mixture

should be gently stirred, to ensure a good mix. The ladle should be thoroughly cleaned before using to ensure freedom from contamination by residues or oxides of other metals used previously.

For most effective use the finished solder should be produced in the form of small diameter rods, or thin flat strips. If round rods are preferred, these should be about 1/4 in. diameter; whilst the flat strip form should be approximately 1/8 in. thick by 3/8 in. wide.

To reproduce such forms the molten solder is run into simple channels cut in a plaster of paris mould, which may be conveniently contained within a wooden box about 12 in. long.

When applying this solder, much care is required to ensure that the surfaces of the aluminium parts to be jointed are perfectly clean. Both surfaces should be lightly ground immediately before soldering, and should not be fingered after that grinding operation. A clean and dry brush should be used to remove grinding particles.

The aluminium articles should be heated and not the rod of solder. The latter should be worked smoothly and gently over the heated surfaces of the parts, and it will quickly begin to run freely, since the solder has a much lower melting-point than the aluminium.

Both jointing surfaces are "tinned" in this manner, and then held together for further heating to bring the deposited solder again to the molten state to complete the joint.

For relatively small parts the soldering may be completed in the above manner without having to use a flux.

Oxidation will be easily avoided, because the aluminium is not raised to a very high temperature; its surfaces will have been thoroughly cleaned by the light grinding, and the soldering will be extremely rapid.

A very strong durable soldered joint can be readily made from this solder, and its use is to be recommended by reason of its simplicity, low cost, and easy application.

-W.M.H.